

Version: RR190604.01

Serial No.: _____

Production Date: _____

USER'S MANUAL

ELECTRO-HYDRAULIC FOUR-POST LIFT

MODEL: TFA4500-3D
TFA5000-3D
TFA5500-3D
TFL5000-3D

TABLE OF CONTENTS

Chapter 1 DESCRIPTION OF THE MACHINE	1
1.1 FIXED STRUCTURE ASSEMBLY.....	1
1.2 MOVABLE STRUCTURE.....	2
Chapter 2 SPECIFICATIONS	4
2.1 OVERALL DIMENSIONS	4
2.2 TECHNICAL SPECIFICATION.....	6
2.3 ELECTRIC MOTOR	6
2.4 HYDRAULIC PUMP.....	6
2.5 OIL.....	6
2.6 TYPES OF VEHICLES SUITABLE FOR BEING LIFTED AND OVERALL DIMENSIONS	7
Chapter 3 SAFETY	8
Chapter 4 INSTALLATION	13
4.1 ASSEMBLY OF MOVABLE STRUCTURE (PLATFORM).....	14
4.2 POST ASSEMBLY.....	15
4.3 HYDRAULIC SYSTEM CONNECTION.....	17
4.4 ELECTRICAL SYSTEM CONNECTION.....	17
4.5 CABLE PRE-ADJUSTMENT.....	18
4.6 SECURE THE POSTS TO THE GROUND.....	18
4.7 INSTALLING THE VEHICLE RAMPS AND THE WHEEL STOPS.....	19
4.8 ADJUSTING THE LIFTING CABLES.....	19
4.9 PRELIMINARY TESTS AND INSPECTIONS BEFORE STARTING.....	20
Chapter 5 OPERATING PRINCIPLES AND USE	21
Chapter 6 MAINTENANCE	22
Chapter 7 TROUBLESHOOTING	25
APPENDIX A SPECIAL INFORMATION	26
APPENDIX B HYDRAULIC DIAGRAM	27
APPENDIX C ELECTRICAL WIRING DIAGRAM	28
APPENDIX D SPARE PARTS	31

Chapter 1. DESCRIPTION OF THE MACHINE

Four-post lifts are fixed installations, i.e. anchored to the floor; the units are designed and built for lifting cars and vans and holding them in an elevated position.

The units are essentially made up of a fixed part that is anchored to the floor (posts) and a moving part (cross-pieces and platforms). The operation is electro-hydraulic.

There are four basic parts of the lifts:

- Fixed structure assembly;
- Movable structure assembly;
- Lifting assembly;
- Safety devices.

Fig. 1 shows the various parts of the lift and the operating zones in the surrounding area.

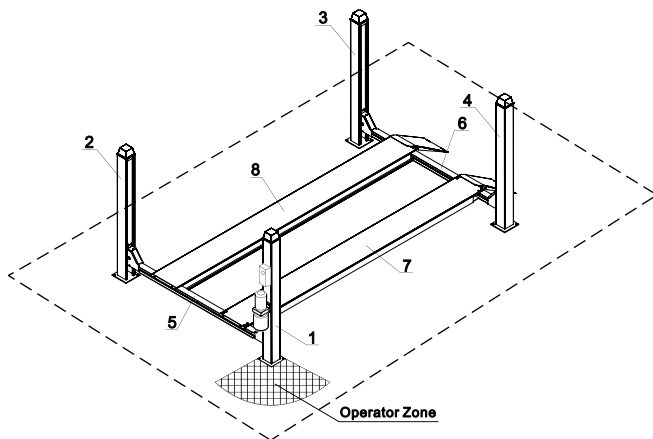

Fig. 1

The lift is composed of the following main parts:

- Control side post (conventionally the front right-hand post) (**Fig. 1-1**)
- Front left post (**Fig. 1-2**)
- Rear left post (**Fig. 1-3**)
- Rear right post (**Fig. 1-4**)
- Control side cross-piece (front cross-piece) (**Fig. 1-5**)
- Rear cross-piece (**Fig. 1-6**)

- Right fixed platform (**Fig. 1-7**)
- Left moving platform (**Fig. 1-8**)

Operator side: this is the front of the lift, including the area reserved for the operator with the control panel. The operator side is opposite the vehicle access side.

Rear side: it is the side opposed the operator's one, with the lift access ramps.

Right and left sides: the right and left is considered from the operator's standpoint when facing the lift.

Danger zone: an area that must be kept clear of persons when the lift is in use; refer to **Chapter "Safety devices"** for details.

1.1 FIXED STRUCTURE ASSEMBLY

The structure includes the four vertical posts in bent steel plate with a pre-drilled base plate for expansion anchors to secure the unit to the floor (*see Chapter 4 "Installation"*).

Each post houses:

- a safety rod with slots (**Fig. 2-2**) to engage the safety wedges;
- a steel cable for lifting (**Fig. 2-1**);
- a guide for the cross-piece vertical sliding (**Fig. 2-3**).

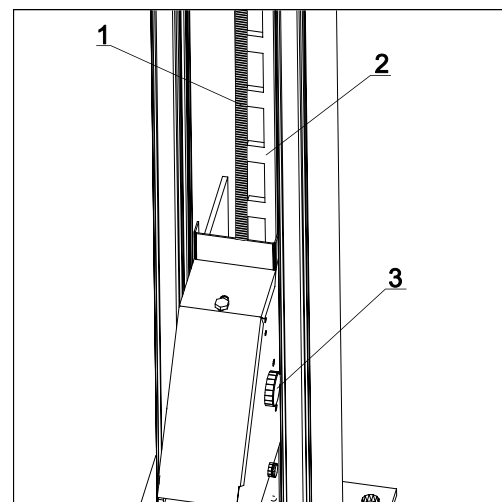

Fig. 2

The following parts are anchored to the top of each post:

- End of safety rod (**Fig. 3-2**), (secured with M20 nut and lock nut, class 8.8);

- The end of the steel cable (**Fig. 3-1**), which is fitted with an M20 threaded shank (fixed with M20 nut and lock nut, class 6S).

The length of the cables can be perfectly adjusted, also to take up slack due to stretching, thanks to the length of the threaded shanks on the ends of the cables.

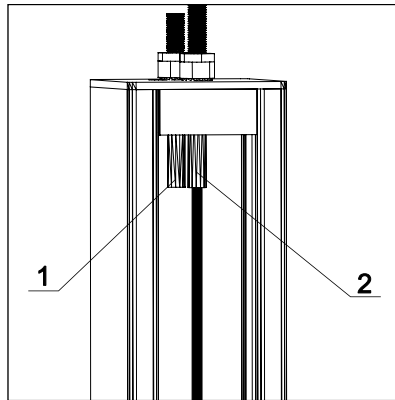

Fig. 3

1.2 MOVABLE STRUCTURE

The movable structure consist of two cross-pieces and two platforms.

Each cross-piece translates vertically between two posts.

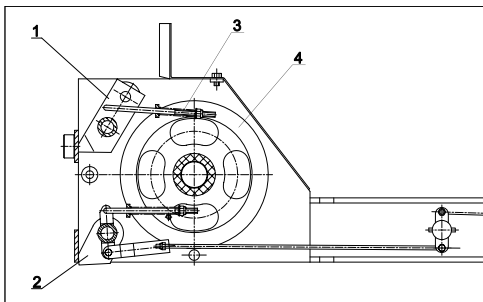

Fig. 6

As shown in **Fig.6**, the ends of the cross-pieces are fitted with the following parts:

- Return pulleys (**Fig. 6-4**) for the lift cable
- Mechanical safety devices (wedges) (**Fig. 6-1 and Fig. 6-2**)

The wedge (**Fig. 6-2**) will engage automatically during lifting and when the lift is raised. To start the LOWERING cycle the wedges must be disengaged by hand or using an electro-pneumatic control (optional) when lowering.

The safety wedge (**Fig. 6-1**) take the weight in the event of a cable failure; the wedge automatically engages with

the safety rods and immediately stops the movable section of the lift together with the vehicle; the cable micro-switch disconnects the electrical parts.

The two platforms (**Fig. 7**) are supported on the cross-pieces.

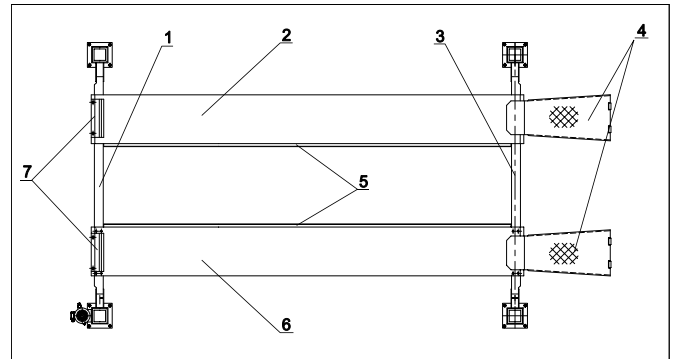

Fig. 7

The right platform (**Fig. 7-6**) has no adjustment; the left platform (**Fig. 7-2**) is free to slide across the width of the lifting area to adapt to the track width of the vehicle being lifted.

Both platforms have inside rails (**Fig. 7-6**) for rolling jack, and fixed wheel stops (**Fig. 7-7**) to stop the vehicle from going beyond the ends of the platforms.

The access ramps (**Fig. 7-4**), pivoted to the platforms, automatically reach a vertical position when the platforms lift, thereby securing the vehicle also from the access end.

The following components are located beneath the fixed platform (**Fig. 8**), and are accessible only from underneath:

- Hydraulic lift cylinder (**Fig. 8-3**)
- Parachute safety valve (**Fig. 8-2**)
- Clevis coupling (**Fig. 8-1**) for the steel cables
- Two cable return pulley assemblies (**Fig. 8-4**)

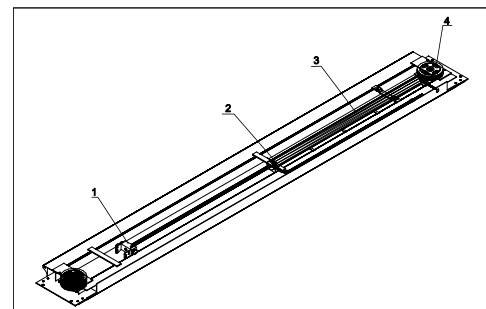
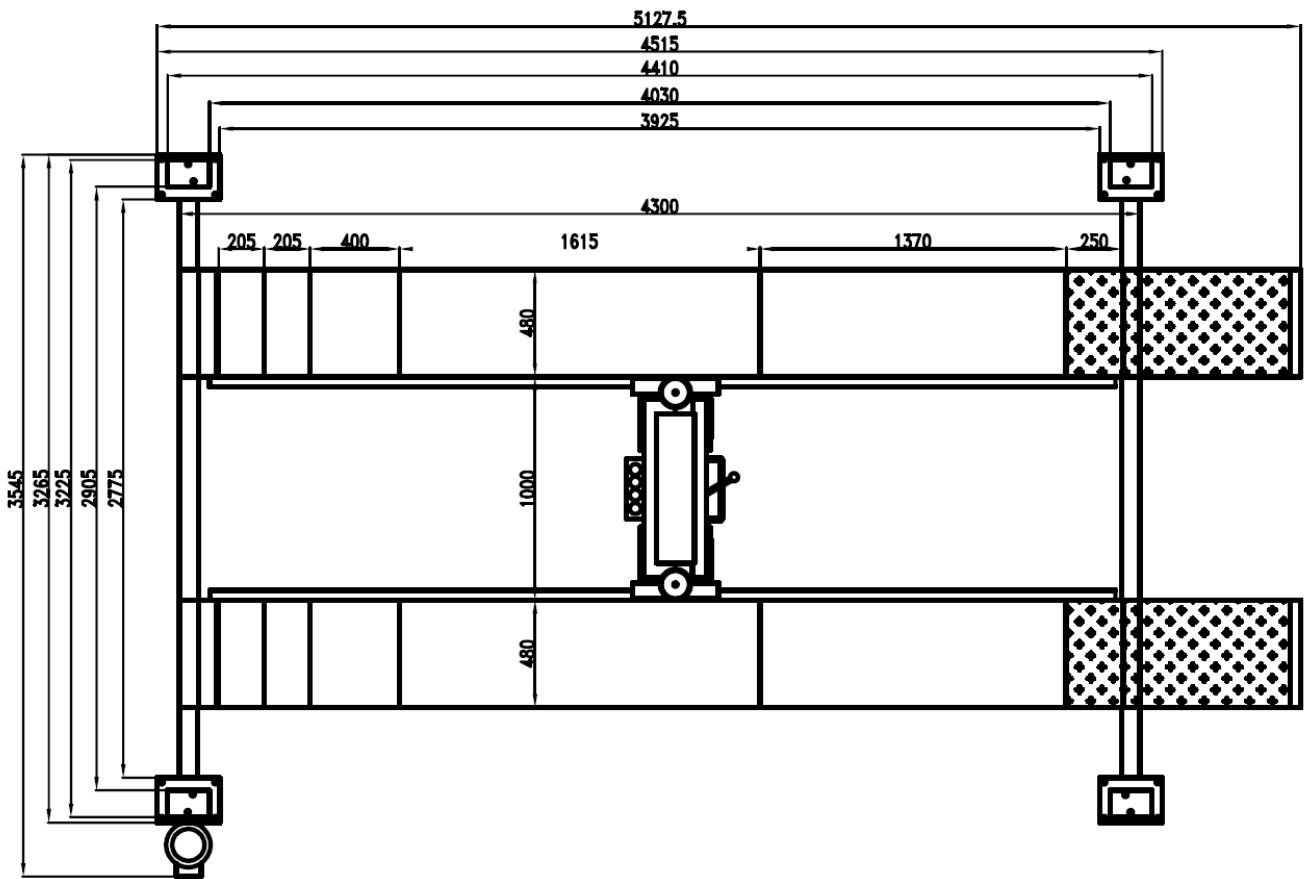
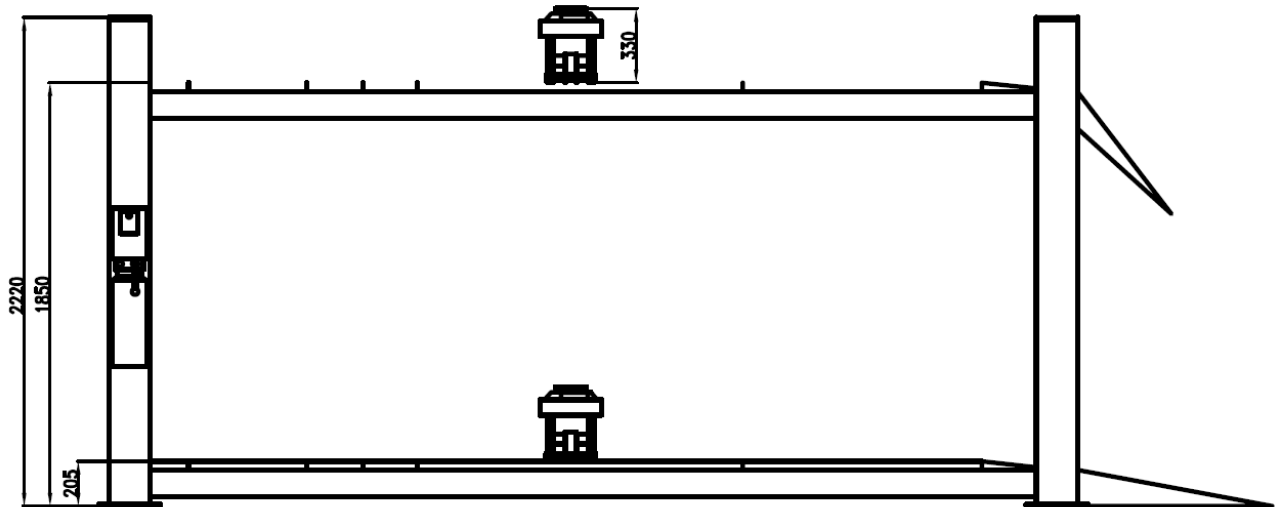

Fig. 8

Chapter 2 SPECIFICATIONS

2.1 OVERALL DIMENSION

TFA4500-3D



TFA5000-3D

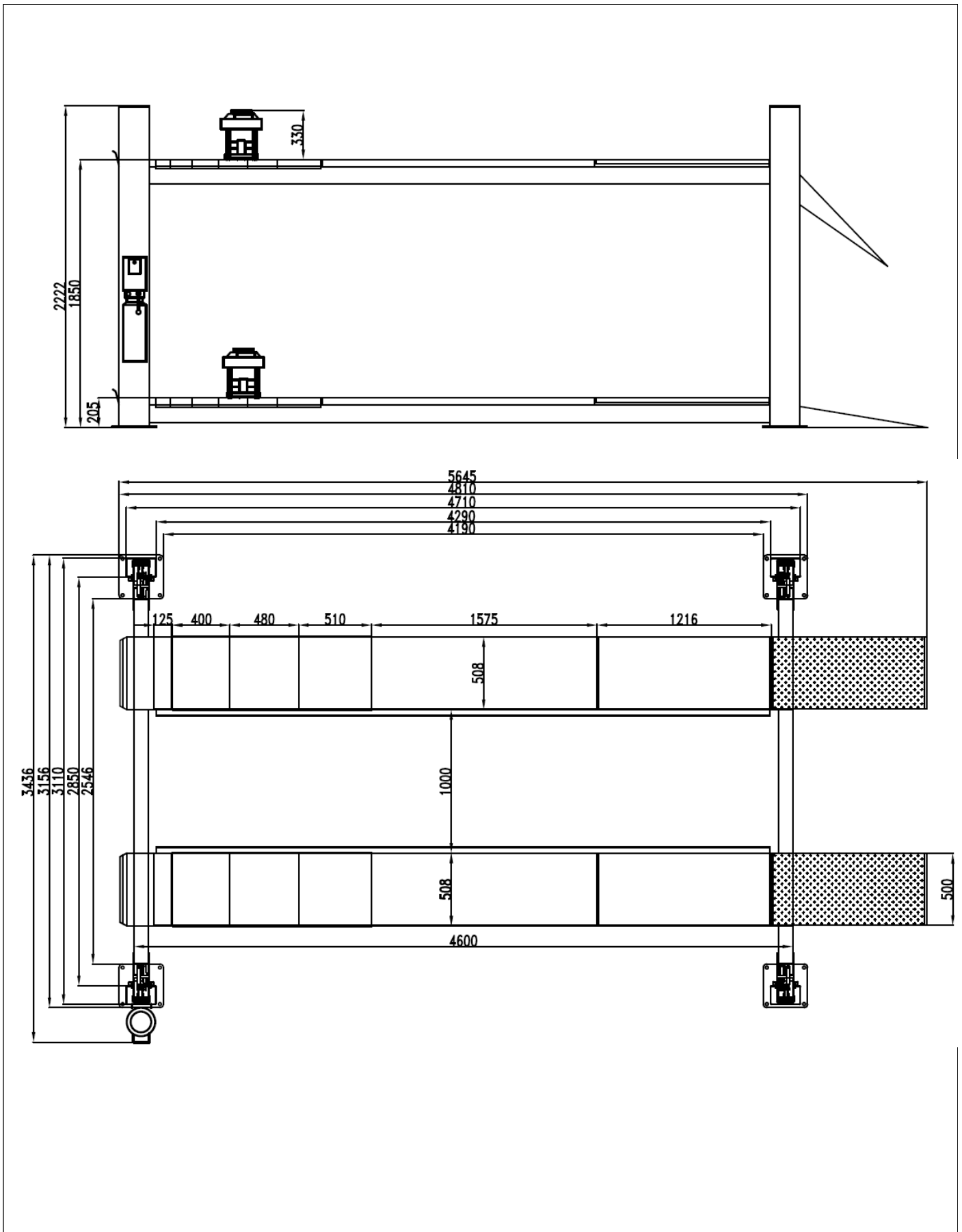

TFA5500-3D

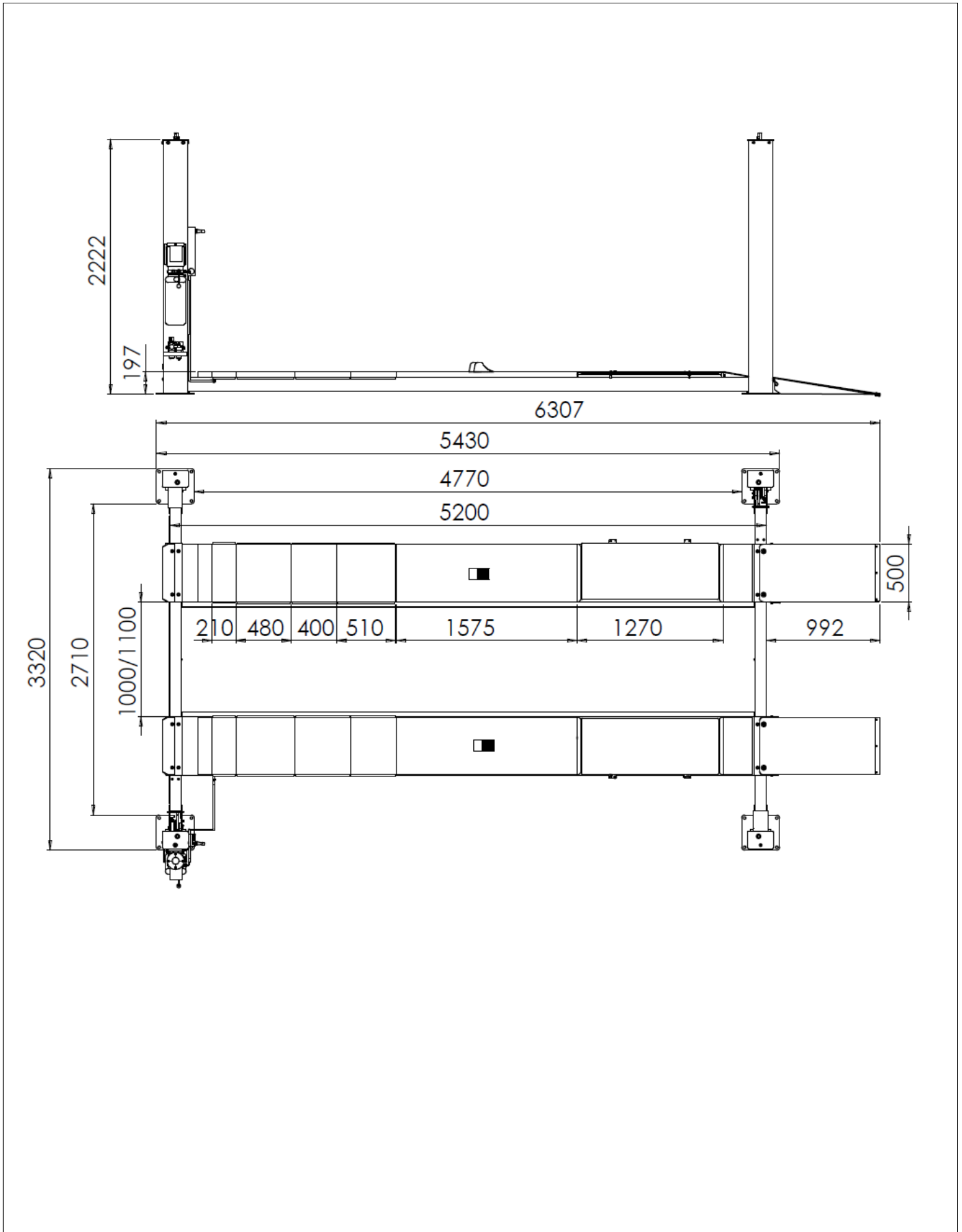

TFL5000-3D

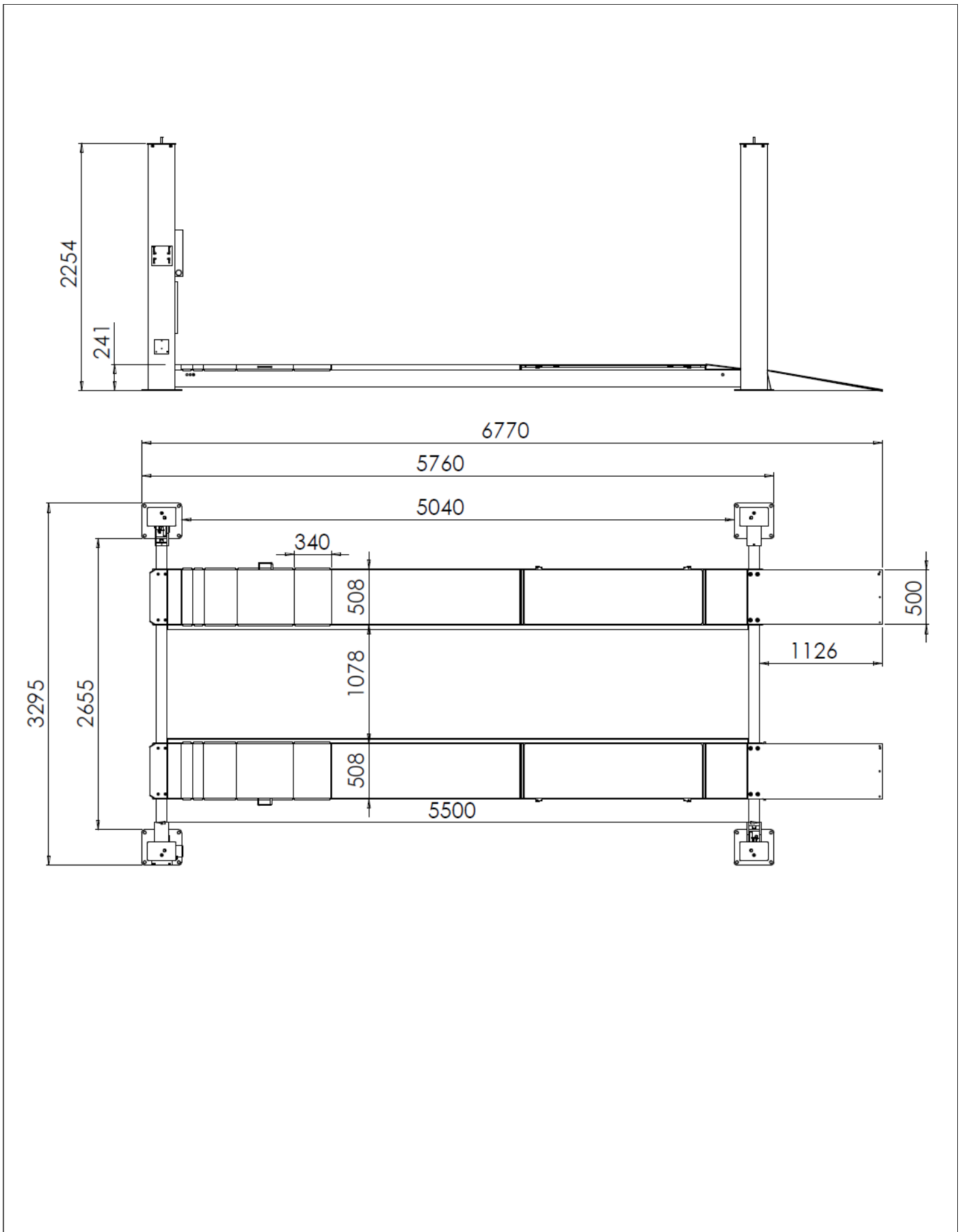

2.2 TECHNICAL SPECIFICATION

MODEL	TFA4500-3D	TFA5000-3D	TFA5500-3D	TFL5500-3D
Driving Mode	Electro-hydraulic			
Capacity	4000kg	5000kg	5500kg	5500kg
Max. Lifting Height	1645mm			
Min. Height	205mm	205mm	197mm	241mm
Platform Length	4300mm	4600mm	5200mm	5500mm
Platform Width	480mm			
Width between Columns	2905mm	2850mm	3015mm	2895mm
Lifting Time	≤60S			
Lowling Time	≤30S			
Overall Width	3265mm	3156mm	3320mm	3295mm
Overall Length	5127mm	5645mm	6307mm	6770mm
Power	AC 110V/220V/230V/380V 50 Hz/60 Hz			
Working Temperature	5-40°C			
Working Humidity	30-95%			
Noise Level	<76db			
Installation Altitude	≤1000m			
Storage Temperature	-25-55°C			

Table 1

2.3 ELECTRIC MOTOR

Type	C90
Power	2.2 Kw
Voltage	230-400V 3ph. +/-5%
Frequency	50 Hz
Poles	4
Speed.....	1400 rpm
Building shape.....	B 14
Insulation class.....	F
Absorption	230V: 10,7A
.	400V: 6,2A

When connecting the motor refer to the enclosed wiring diagrams, the motor has left-handed rotation (counter-clockwise) as shown on the data plate on the casing.

2.4 HYDRAULIC PUMP

Type	18
Model	10A5x348
Displacement	5 cc/rev.
Relief valve set-up	160 bar

2.5 OIL

The hydraulic oil reservoir is filled with mineral oil to ISO/DIN 6743/4, contamination category no higher than class 18/15 according to ISO 4406, such as IP HYDRO OIL 32; SHELL TELLUS T37 or an equivalent oil.

2.6 TYPES OF VEHICLES SUITABLE FOR BEING LIFTED AND OVERALL DIMENSIONS

Model TFA4500-3D lifts are suitable for virtually all vehicles with total weight of no more than 4000kg.

Model TFA5000-3D lifts are suitable for virtually all vehicles with total weight of no more than 5000kg.

Model TFA5500-3D lifts are suitable for virtually all vehicles with total weight of no more than 5500kg.

Model TFL5000-3D lifts are suitable for virtually all vehicles with total weight of no more than 5500kg.

The vehicle dimension shall not exceed the below data:

Max. width: 2400 mm.

Max. wheelbase: 3000 mm.

Max. distance between outer wall of tyres, inclusive of bulge caused by weight of vehicle on ground: 2000 mm.

Min. distance between inner walls of tyres, inclusive of bulge caused by weight of vehicle on ground: 900 mm.

Caution: the lower parts of the vehicle underbody could interfere with structural parts of the lift.

Take particular care in the case sports-cars.

The lift will also handle customized or non-standard vehicles provided they are within the maximum specified carrying capacity.

Also the personnel danger zone must be defined in relation to vehicles with unusual dimensions.

The following diagrams illustrate criteria used to define the operating limits of the lift.

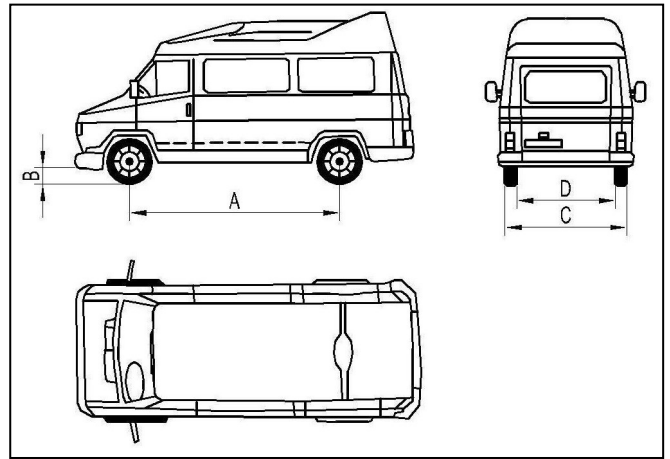

Fig. 11

	Min. (mm)	Max. (mm)
A	2300	4500
B	200	
C		2000
D	900	

Table 2

FOR LARGER DIMENSIONS CHECK THE MAXIMUM LOAD AND POSSIBLE UNBALANCE.

MAXIMUM WEIGHTS OF VEHICLES BEING LIFTED

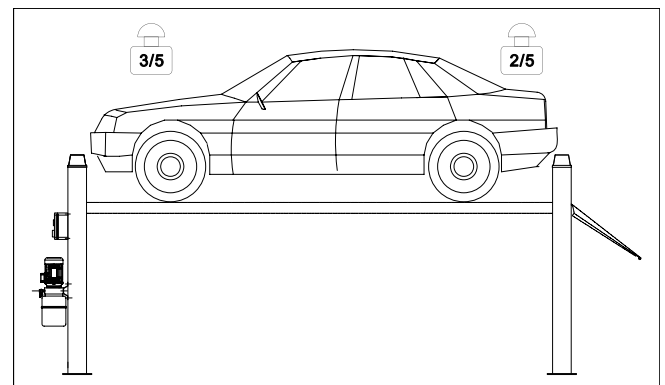

Fig. 12 Weight Distribution

Chapter 3 SAFETY

It is extremely important to read this chapter of the manual carefully and from beginning to end as it contains important information regarding the risks the operator or maintenance fitter may be exposed to if the lift is used incorrectly.

In the following text there are clear explanations regarding certain situations of risk or danger that may arise during the operation or maintenance of the lift, the safety devices installed and the correct use of such systems, residual risks and operative procedures to use (general and specific precautions to eliminate potential hazards).

WARNING:

The lifts are designed and built to lift vehicles and hold them in the elevated position in an enclosed workshop. All other uses of the lifts are unauthorized. In particular, the lifts are not suitable for:

- Washing and respray work;
- Creating raised platforms for personnel or lifting personnel;
- Use as a press for crushing purposes;
- Use as elevator;
- Use as a lift jack for lifting vehicle bodies or changing wheels.

During lifting and lowering movements the operator must remain in the control station as defined in Fig. 13.

The presence of persons beneath the cross-pieces and/or the platforms when they are moving, or the presence of persons inside the danger zone indicated in Fig. 13 is strictly prohibited.

The area occupied from the lift and perimetral band of width 1÷2 mt of the lift are defined as "DANGER ZONE".

The operator parking area, only for actioning the lift, is defined as "ZONE OPERATOR".

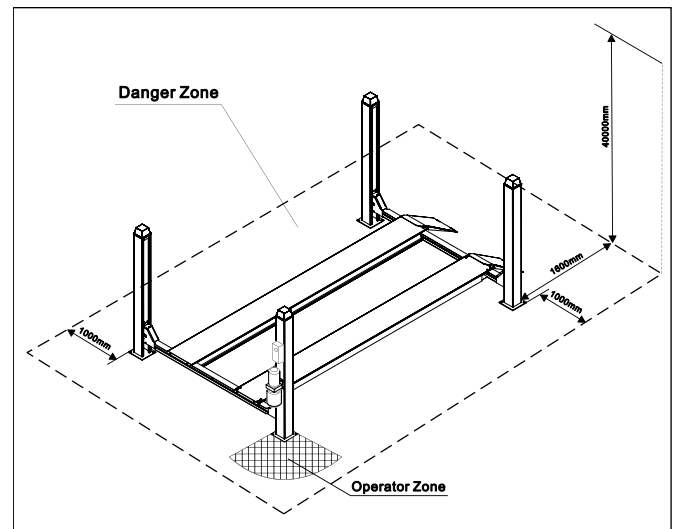

Fig. 13

During operations persons are admitted to the area beneath the vehicle only when the vehicle is already in the elevated position, when the cross-pieces and platforms are stationary, and when the mechanical safety devices (wedges) are firmly engaged in the slots on the safety rods.

DO NOT USE THE LIFT WITHOUT PROTECTION DEVICES OR WITH THE PROTECTION DEVICES INHIBITED.

FAILURE TO COMPLY WITH THESE REGULATIONS CAN CAUSE SERIOUS INJURY TO PERSONS, AND IRREPARABLE DAMAGE TO THE LIFT AND THE VEHICLE BEING LIFTED.

GENERAL PRECAUTIONS

The operator and the maintenance fitter are required to observe the prescriptions of safety regulation in force in the country of installation of the lift.

Furthermore, the operator and maintenance fitter must:

- Always work in the stations specified and illustrated in this manual;
- Never remove or deactivate the guards and mechanical, electrical, or other types of safety devices;
- Read the safety notices placed on the machine and the safety information in this manual.

In the manual all safety notices are shown as follows:

DANGER: indicates imminent danger that can result in serious injury to people or death.

WARNING: indicates situations and/or types of maneuvers that are unsafe and can cause more or less harmful injuries or death.

CAUTION: indicates situations and/or types of maneuvers that are unsafe and can cause minor injury to persons and/or damage the lift, the vehicle or other property.

RISK OF ELECTRIC SHOCK: a specific safety notice placed on the lift in areas where the risk of electric shock is particularly high.

RISKS AND PROTECTION DEVICES

We shall now examine the risks that operators or maintenance fitters may be exposed to when the vehicle is standing on the platforms in the raised position, together with the various safety and protection devices adopted by the manufacturer to reduce all such hazards to the minimum:

LONGITUDINAL MOVEMENTS

Longitudinal movements refer to forward and backward movement of the load (vehicle).

To protect against the consequences of longitudinal movement, the lift is installed with fixed wheel stops at the front of the lift, and pivoting stops at the rear. The stops are integral with the platforms and serve to secure the vehicle during lifting and lowering movements and when the vehicle is at a standstill in the raised position, thus preventing any potentially dangerous movement.

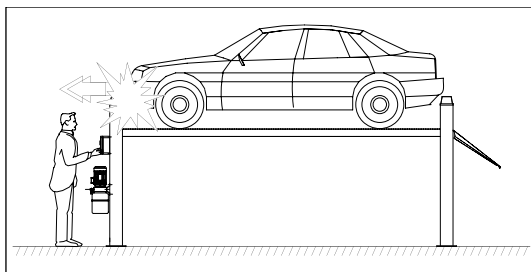

Fig. 14

SIDE MOVEMENTS

Side movements refer to shifting of the vehicle toward the left or right of the lift, especially during the lifting cycle.

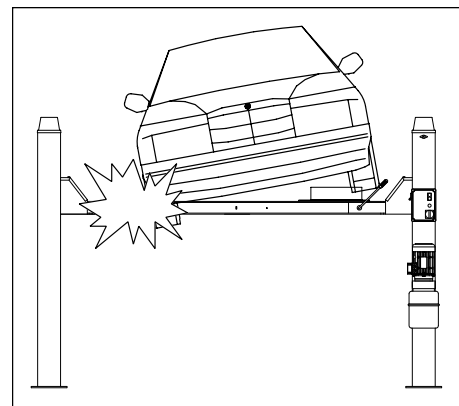

Fig. 15

For optimal personal safety and safety of vehicles, observe the following regulations:

- Do not enter the danger zone while vehicles are being lifted (*see Fig. 13*);
- Switch off the engine of the vehicle, engage a gear and engage the hand brake;
- Make sure the vehicle is positioned correctly (*Fig.16*);

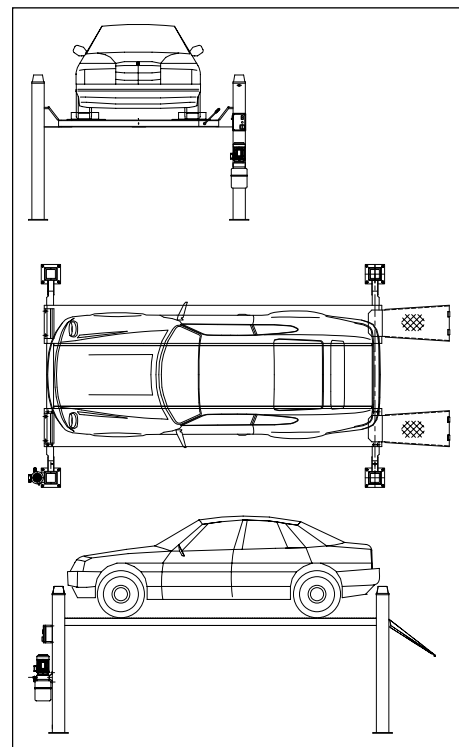

Fig. 16

- Be sure to lift only approved vehicles, never exceed the specified carrying capacity, maximum height, and projections (vehicle length and width);

- Make sure that there are no persons on the platforms during up and down movements and during standing (Fig. 17).

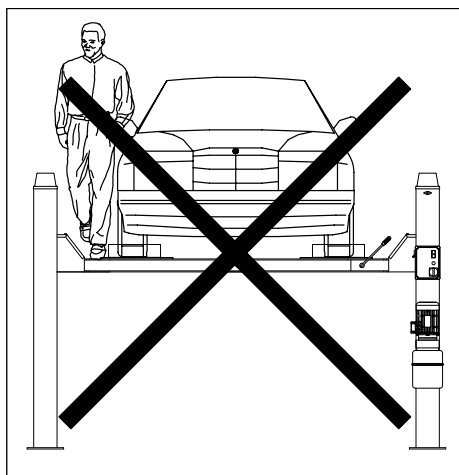

Fig. 17

POTENTIAL RISKS DURING LIFTING

The following safety devices are installed to protect against overloads and possible mechanical failures:

In the case of excess weight on the lift the relief valve on the hydraulic power unit will open (Fig. 18).

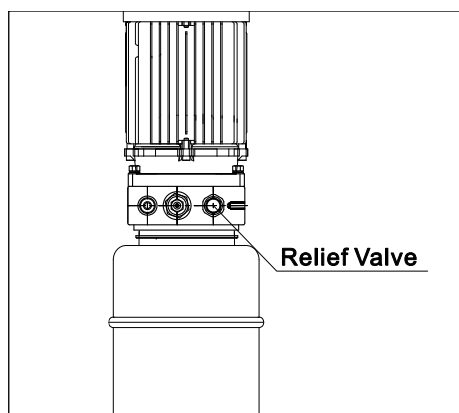

Fig. 18

If one or more hoses in the hydraulic circuit should break, a cylinder locking valve will operate (Fig. 19).

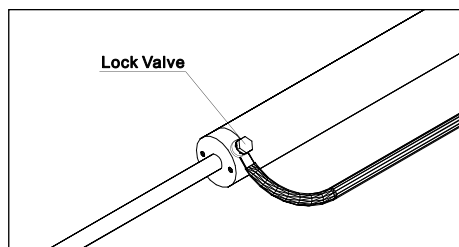

Fig. 19

If the movable part of the lift should go in overstroke, there is an electric limit switch (Fig. 20) in the control post and a steel locking plate on the top of all four posts.

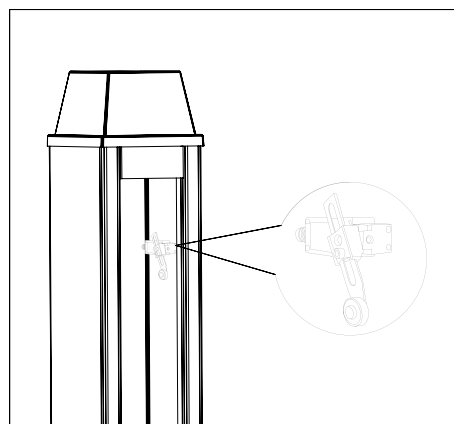

Fig. 20

Should the steel cables slacken or break, the safety wedges will stop the movable part of the lift and the vehicle in its current position (Fig. 21).

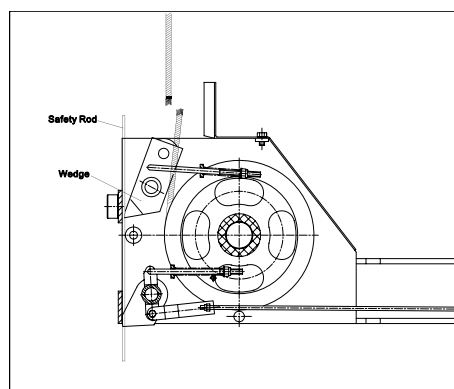

Fig. 21

RISKS FOR PERSONNEL

This heading illustrates potential risks for the operator, maintenance fitter, or any other person present in the area around the lift, resulting from incorrect use of the lift.

RISK OF CRUSHING (OPERATOR)

Possible if the operator controlling the lift is not in the specified position at the control panel.

When the platforms (and vehicle) are lowering the operator must never be partly or completely underneath or near of the movable structure. Always remain in the operator zone (Fig. 13).

RISK OF CRUSHING (PERSONNEL)

When the platforms and the vehicle are lowering, personnel are prohibited from entering the area beneath the movable

parts of the lift (**Fig. 22**). The lift operator must not start the maneuver until it has been clearly established that there are no persons in danger zone.

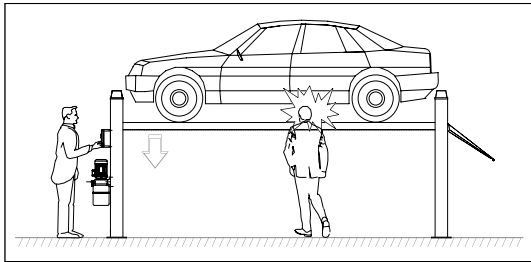

Fig. 22

RISK OF IMPACT

Caused by the parts of the lift or the vehicle that are positioned at head height.

When, due to operational reasons, the lift is stopped at relatively low elevations (less than 1.75 m from the ground) personnel must be careful to avoid impact with parts of the machine not marked with special colors (**Fig. 23**).

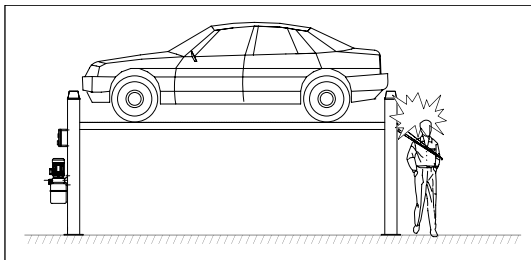

Fig. 23

RISK OF VEHICLE MOVING

Caused by operations involving the application of force sufficient to displace the vehicle.

In the case of large or particularly heavy vehicles, sudden movement could create an unacceptable overload or uneven loadsharing.

Therefore, before lifting the vehicle and during all operations on the vehicle

MAKE SURE THAT IT IS PROPERLY STOPPED BY THE HAND BRAKE.

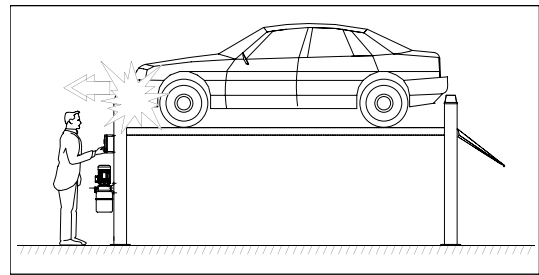

Fig. 24

RISK OF VEHICLE FALLING FROM LIFT

This hazard may arise in the case of incorrect positioning of the vehicle on the platforms, incorrect stopping of the vehicle, or in the case of vehicles of dimensions that are not compatible with the capacity of the lift.

NEVER ATTEMPT TO PERFORM TESTS BY DRIVING THE VEHICLE WHILE IT IS ON THE PLATFORMS (e.g. reversing, etc.).

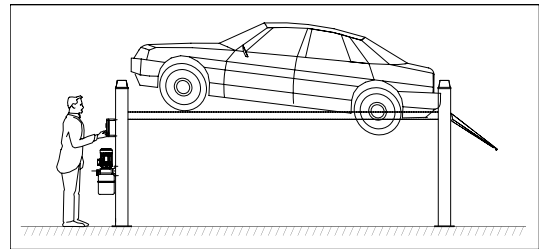

Fig. 25

RISK OF SLACKENING OF LIFT CABLES

Caused by objects left leaning against the posts or on the platforms (**Fig. 26**).

NEVER LEAN OBJECTS AGAINST THE POSTS OR LEAVE THEM IN THE LOWERING AREA OF THE MOVABLE PARTS OF THE LIFT.

If you leave objects that interfere with the free lowering of the platforms, the lowering movement will be interrupted.

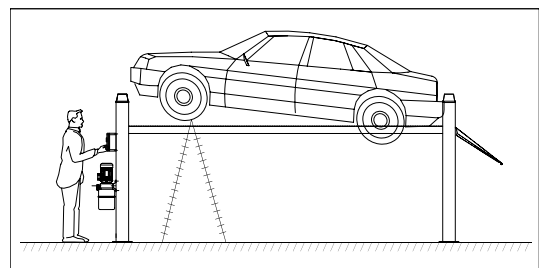

Fig. 26

RISK OF SLIPPING

Caused by lubricant contamination of the floor around the lift (*Fig. 27*).

THE AREA BENEATH AND IMMEDIATELY SURROUNDING THE LIFT AND ALSO THE PLATFORMS MUST BE KEPT CLEAN. Remove any oil spills immediately.

When the lift is fully down, do not walk over the platforms or the cross-pieces in places that are lubricated with a film of grease for functional requirements. Reduce the risk of slipping by wearing safety shoes.

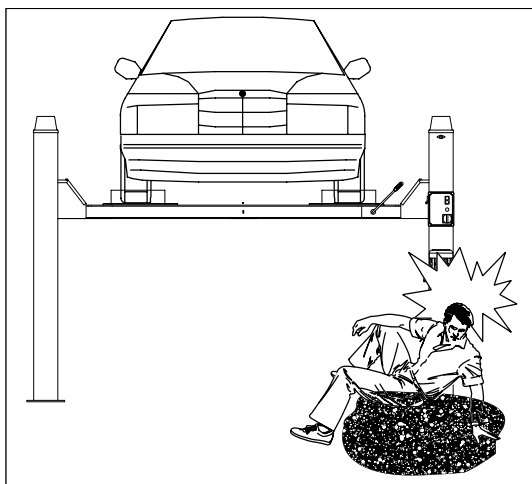

Fig. 27

RISK OF ELECTRIC SHOCK

Risk of electric shock in areas of the lift housing electrical wiring.

Do not use jets of water, steam (high pressure washers units), solvents or paint next to the lift, and take special care to keep such substances clear of the electrical control panel.

RISKS RELATED TO INAPPROPRIATE LIGHTING

The operator and the maintenance fitter must be able to assure that all the areas of the lift are properly and uniformly illuminated in compliance with the laws in force in the place of installation.

RISK OF COMPONENT FAILURE DURING OPERATION

The manufacturer has used appropriate materials and construction techniques in relation to the specified use of the machine in order to manufacture a reliable and safe lift. Note however, that the lift must be used in conformity with manufacturer's prescriptions, and the frequency of

inspections and maintenance works recommended in *chapter 6 "MAINTENANCE"* must be observed.

RISKS RELATED TO IMPROPER USE

Persons are not permitted to stand or sit on the platforms during the lift maneuver or when the vehicle is already lifted.

All uses of the lift other than the uses for which it was designed are liable to give rise to serious accidents involving the persons working nearby.

It is therefore essential to adhere scrupulously to all regulations regarding use, maintenance and safety contained in this manual.

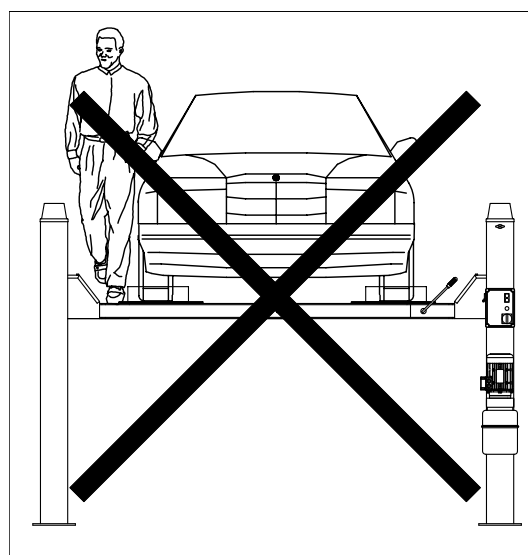

Fig. 28

Chapter 4 INSTALLATION

THE FOLLOWING OPERATIONS MUST BE PERFORMED EXCLUSIVELY BY SPECIALISED TECHNICAL STAFF WITH AUTHORISATION FROM THE MANUFACTURER OR LICENSED DEALER.

IF THESE OPERATIONS ARE PERFORMED BY OTHER PERSONS, SERIOUS PERSONAL INJURY AND/OR IRREPARABLE DAMAGE TO THE LIFT UNIT MAY RESULT.

INSTALLATION REQUIREMENT CHECK

MAKE SURE THAT THE INTENDED PLACE OF INSTALLATION IS SUITABLE.

The lift is designed for installation in enclosed areas suitably protected from weather. The place of installation must be well clear of areas in which washing or painting work is performed, and away from solvent or paint storage areas or areas, where there is a risk of potentially explosive atmosphere.

CHECK OF ROOM SUITABILITY AND SAFETY CLEARANCES.

The lift must be installed in compliance with the clearances between walls, pillars, other machines, etc. indicated in **Fig. 29** and in compliance with any law requirements in the country of installation.

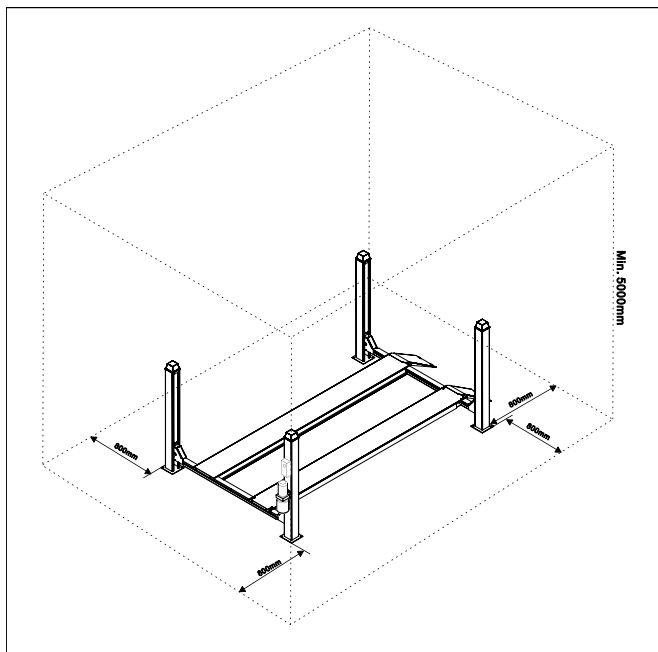

Fig. 29

In any event, there must be a minimum clearance of 800 mm between all movable parts of the lift and the vehicle

itself and the nearest fixed or mobile structures in the workshop.

Check:

- Height: 5000 mm min. (calculate also the height of the vehicles you intend to lift)
- Distance from walls: 800 mm min.
- Working space: 800 mm min.
- CONTROL POSITION area
- Maintenance area
- Access
- Escape routes for emergency situations
- Position in relation to other machines
- Rational orientation of the lift
- Possibility of electrical connection

LIGHTING

All parts of the machine must be uniformly lit with sufficient light to make sure that the adjustment and maintenance operations specified in the manual can be performed safely, and without areas of shadow, reflected light, glare and avoiding all situations that could give rise to eye fatigue.

The lighting must be installed in accordance with the laws in force in the place of installation (responsibility lies with the lighting equipment fitter).

FLOOR

The lift must be installed on a horizontal platform with suitable load capacity.

The platform and the foundations must be suitable to resist the maximum stress values that the lift can transmit to the ground envisaging the worst operating conditions: specific ground pressure exerted by the lift in the prescribed conditions of use is approximately 5 kg/cm².

- Vertical load: 1850 kg
- Shear force: negligible

The floor must be flat and without gradients (maximum of 10 mm tolerance)

INSTALLING WITH EXPANSION ANCHORS

Example of installation on industrial floor in average mix concrete with embedded electrowelded reinforcing mesh, thickness min. 180 mm and properly leveled.

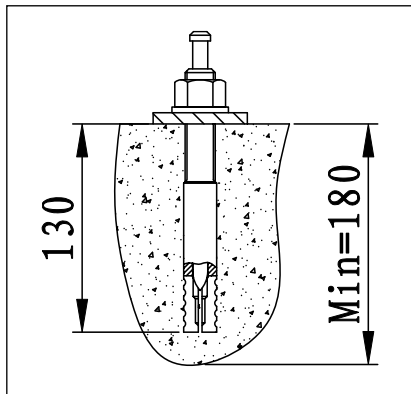

Fig. 30

PREPARING THE FLOOR - MARKING

The measurements shown in the figure are compulsory; maximum tolerance is:

- +/- 1 mm alignment
- +/- 2 mm squaring

WARNING

UNAUTHORISED PERSONS MUST NOT BE ADMITTED DURING ASSEMBLY OPERATIONS.

4.1 ASSEMBLY OF MOVABLE STRUCTURE (PLATFORM)

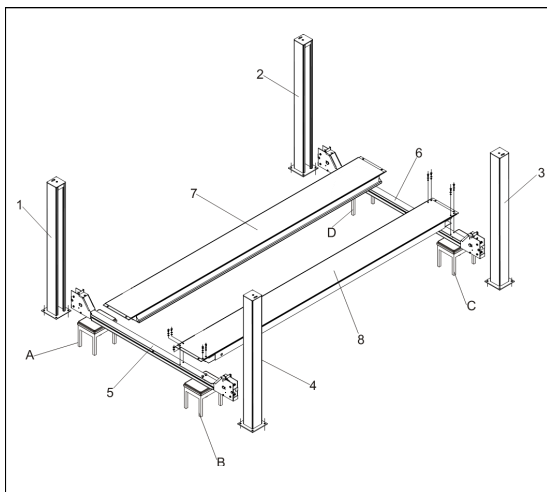

Fig. 32

1 - Place 4 trestles of the same height and suitably sturdy to hold 250 kg each, in the area where you intend to install the lift. Position the trestles as shown in the **Fig. 32-A/B/C/D**.

2 - Remove the posts from the packing (**Fig. 32-1/2/3/4**), together with the movable platform (**Fig. 32-7**), the hydraulic power unit and accessories.

3 - Place the fixed platform (**Fig. 32-8**) on two trestles (**Fig. 32-B/C**) together with the two cross-pieces (**Fig. 32-5/6**).

4 - Place the cross-piece (**Fig. 32-5**) on trestle (**Fig. 32-A**) and secure it to the fixed platform (**Fig. 32-8**).

During these operations check that the steel cables are correctly positioned (Fig. 33).

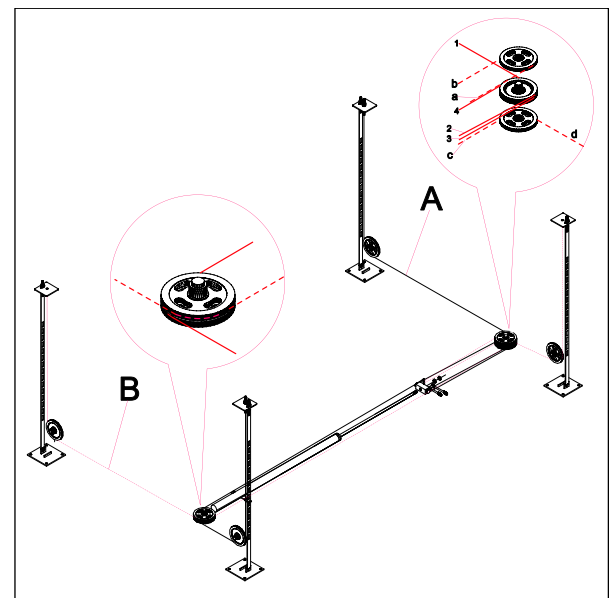

Fig. 33

5 - Place the movable platform (**Fig. 32-7**) on the cross-pieces (**Fig. 32-5/6**).

6 - Check squaring and the diagonals of the cross-piece - platform assembly; check also that the movable platform runs smoothly between the cross-pieces; then, fully tighten the screws securing the fixed platform.

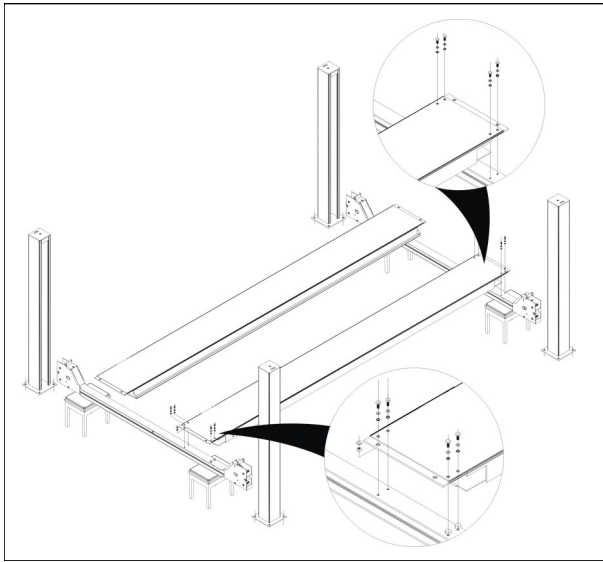

Fig. 34

When you are installing the cross-piece, fit the wedge control rod between the two cross-pieces; the rod is engaged on side “A” and fastened on side “B” by M6 x 20 screws and 6 x 12 plane washers (Fig. 35).

Repeat this operation for the cross-piece (Fig. 32-6).

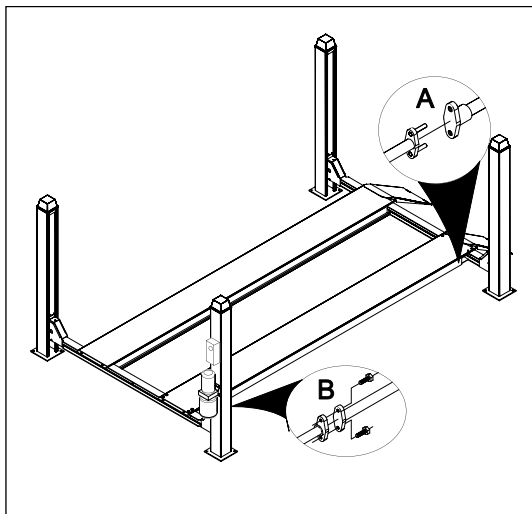

Fig. 35

4.2 POST ASSEMBLY

Remove the safety rods from the top of the posts as shown in Fig. 36.

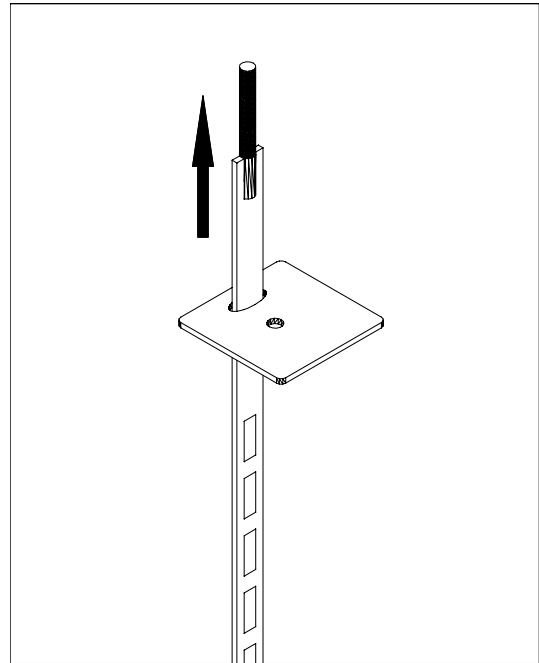

Fig. 36

Preparation of the control post

The control post is distinguished from the others because it has drilled holes to receive the control panel and the hydraulic power unit.

Secure the hydraulic power unit and control panel to the control post. (Fig. 37)

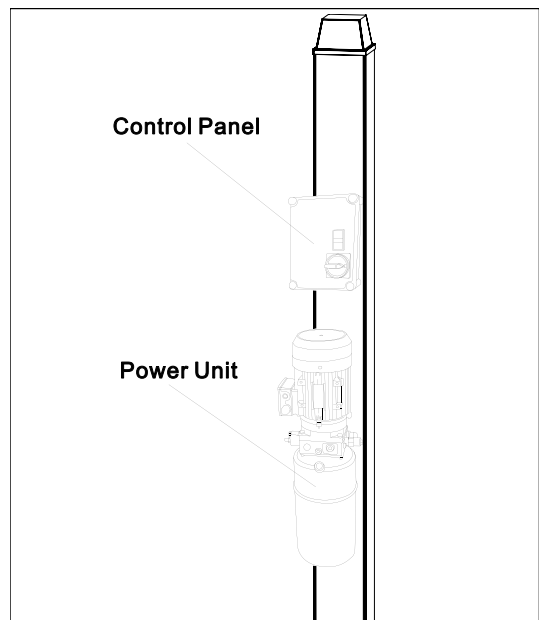

Fig. 37

Install the lift limit switch on the top inside of the post according to Fig. 38.

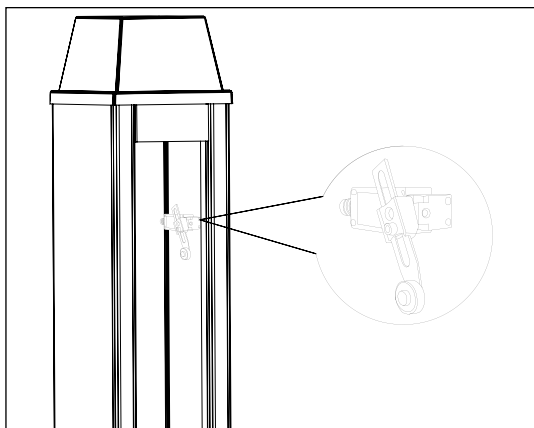

Fig. 38

Install the lowering micro-switch to the bottom of the post as shown in **Fig. 39**.

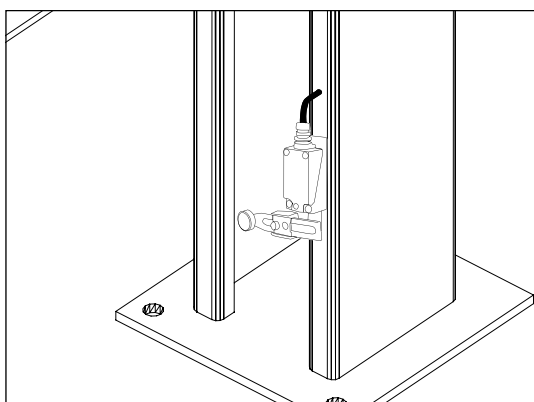

Fig. 39

Install the warning buzzer to the top of the post according to **Fig. 40**.

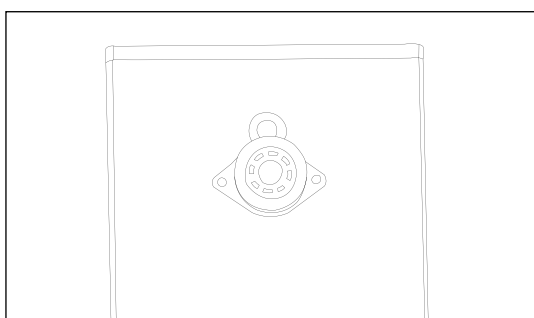

Fig. 40

Position the posts at the end of the cross-pieces observing the numbering and the lay-out shown in **Fig. 32**.

Fit the safety rods (**Fig. 41-1**) from the top of the posts, inserting them between the rear face of the cross-pieces and the guide pins (**Fig. 41-2**) as shown in **Fig. 41**.

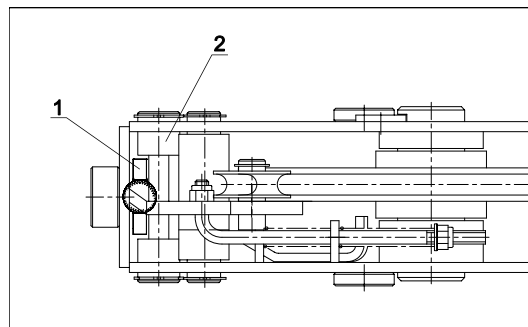

Fig. 41

Check the Safety rods are straight.

Fit the Safety rods with the rounded edges of the slots towards the front of the posts.

Now secure the bottom end of the rods as shown in **Fig. 42**.

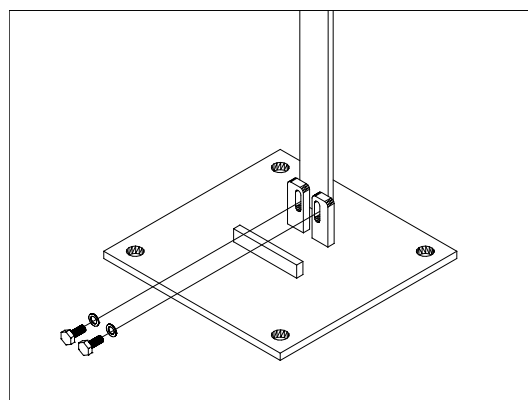

Fig. 42

Remove the nuts and washers from the ends of the lifting cables and install the terminal blocks in the relevant holes on the top plates of the posts (**Fig. 43**).

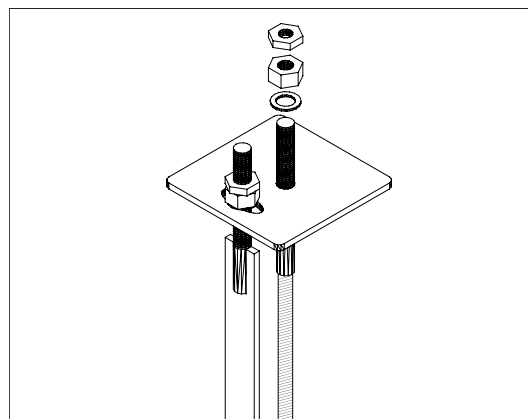

Fig. 43

Screw the nuts and washers onto the terminal blocks. During this procedure, make sure that the cable wheel of the safety wedge are correctly positioned on the lifting cables as shown in **Fig. 44**.

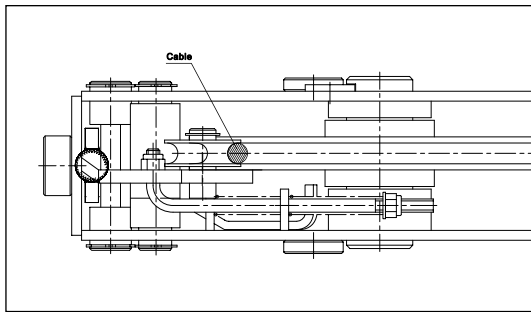

Fig. 44

4.3 HYDRAULIC SYSTEM CONNECTION

Connect high pressure rubber hose to the union mounted on the hydraulic power unit with the washers and the drill screw to equipment and tighten it fully down.

4.4 ELECTRICAL SYSTEM CONNECTION

Before connecting the electric system, make sure that:

the power supply plant to the lift is equipped with the protection devices required by current standards in the country where the machinery is installed.

WARNING

The electric panels are arranged by the manufacturer for operating at 400 V, three-phase.

Once checked if everything is complying, close the panel and check, by making the lift rise, the motor rotation direction: it should be the same of the one on the plate of the motor.

If the rotation direction isn't complying, open the panel again, reverse two wires of the phases as per **Fig. 47**, close the panel again and check the rotation direction.

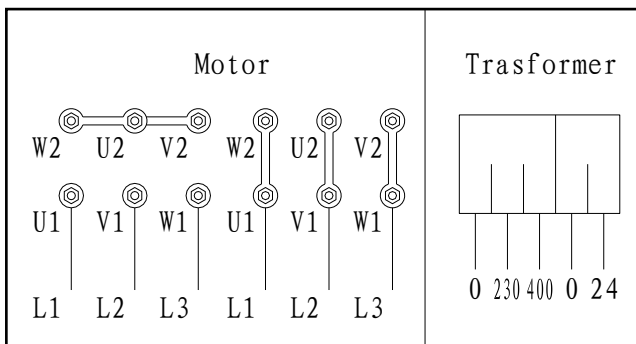

Fig. 47

WARNING

ALL THE ABOVE OPERATIONS MUST BE MADE ONLY BY SKILLED PERSONNEL.

Before making any maneuvers:

- 1) Check the fluid level, and fill if necessary using mineral oil for hydraulic system ISO 32 - H-LP DIN 51525.
- 2) Check the rotation direction of the motor by pushing the lifting pushbutton momentarily.

WARNING: prolonged rotation in the wrong direction can seriously damage the pump.

- 3) Adjust the opening of the wedges. Keeping the descent button pressed, check the distance between the safety device and the rod is 5 mm. A lesser space could cause the safety device hooking, while a greater space could prevent a perfect electromagnet closure with consequent noisy vibration.

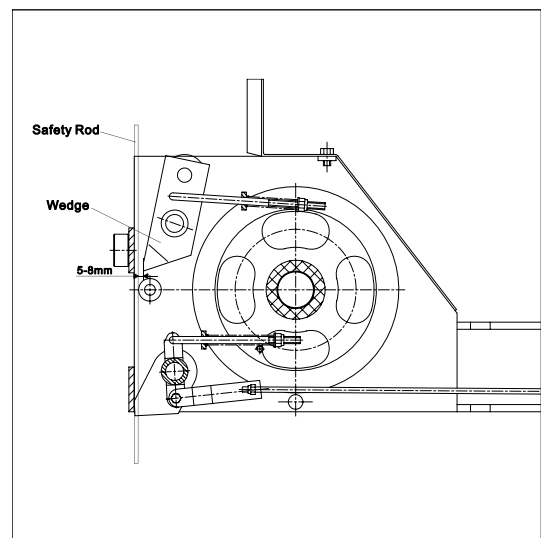

Fig. 48

4.5 CABLE PRE-ADJUSTMENT

Close the panel, put the switch (QS) in pos. 1 and make the lift rise until clearing the wedges; then put the switch in position 0 and close them again.

Position the lift so that the four wedges are firmly seated in the slots on the safety rods (**Fig. 48-3**). Adjust the nuts (**Fig. 48-2**) on the terminal blocks of the lift cables (**Fig. 48-4**) to level the platforms so that the entire surface of the movable section of the lift is perfectly level.

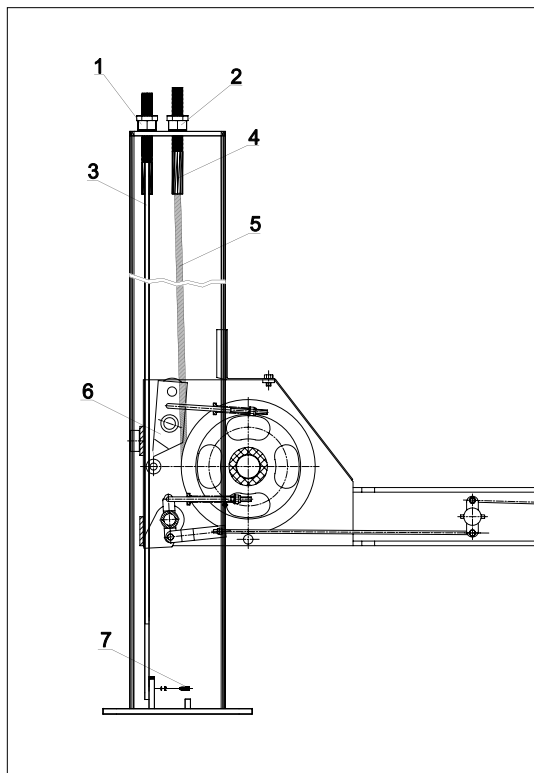

Fig. 49

Loosen the lower screws (**Fig. 49-7**) securing the safety rods and, by turning the upper nuts (**Fig. 49-1**) of the rods, adjust so that the distance between the wedges and the slots in the safety rods is identical on all four posts. Tighten the lower screws fully and secure the upper part with the lock nut.

4.6 SECURING THE POSTS TO THE GROUND

Lower the platform (*see operating instructions*) until it is about 30 cm from the ground.

Position the posts so that the nylon shoes (**Fig. 50-1 and Fig. 50-2**) are in contact with the posts.

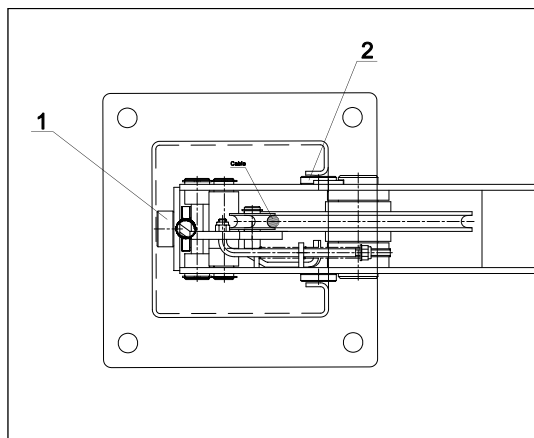

Fig. 50

Plumb the posts to ensure that they are perfectly perpendicular to the floor, inserting shims where necessary under the baseplates.

Use shims that are as large as possible and always install them close to the anchor holes.

Press LIFT button and complete the lift cycle; during the cycle. Check that the cross-pieces slide freely and without undue rubbing friction (you may want to stop the lift motion every 20 or 30 cm to make this inspection easier).

If you notice any malfunctions during this operation, check that the posts are perfectly perpendicular.

When the lift cycle is completed, make sure that the lifting limit switch is working properly and if necessary, adjust using the cam on the cross-piece.

Lower the platform until it is about 30 cm from the ground and then drill into the floor through the fixing holes in the base plates.

Use screw anchors size \varnothing 16 mm, M10, length 65 mm, type FISCHER SLM 10 or equivalent (HILTI HB M10). Tighten the screws with a torque.

4.7 INSTALLING THE VEHICLE RAMPS AND THE WHEEL STOPS

The vehicle ramps (**Fig. 51**) and the wheel stops (**Fig. 52**) can be fitted on either end of platforms according to the user's requirements.

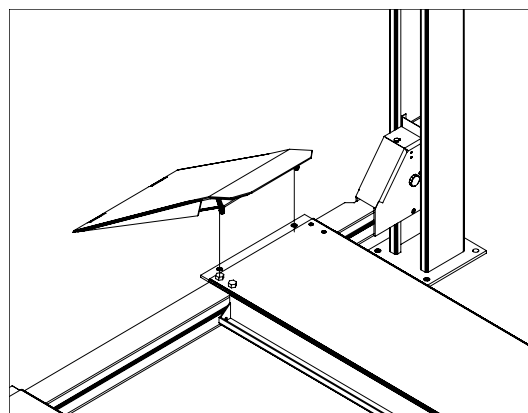

Fig. 51

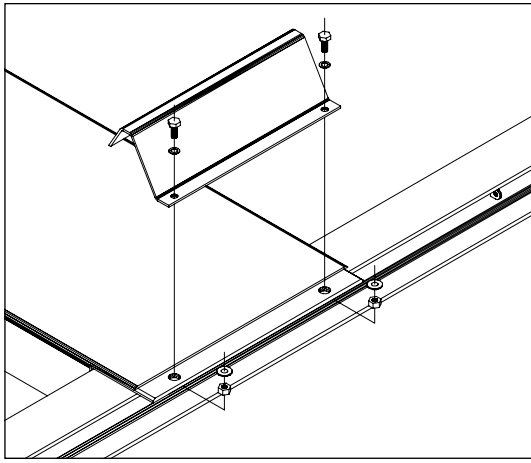

Fig. 52

Fit the ramps by slotting them into the platforms on the required end and then fix the wheel stops on the opposite.

4.8 ADJUSTING THE LIFTING CABLES

Drive a vehicle onto the lift.

Raise the lift to the maximum height and check if the four wedges are fitted inside the slots of the safety rods.

Check if the distance between the wedges and the slots of the safety rods on the 4 posts is at least 20 mm from the support; a lower value would not allow the safety device to rotate, and it would stay attached to the rod.

If necessary, level the unit by adjusting the nuts on the terminals of the cables and the limit micro switch.

When the adjustment is completed, lock with the lock nuts.

IMPORTANT: *This adjustment must be repeated 1 or 2 weeks after setting up the lift.*

4.9 PRELIMINARY TESTS AND INSPECTIONS BEFORE STARTING

MECHANICAL CHECKS

- Leveling and alignment;
- Tightness of bolts, unions and connections;
- Free movement of all moving parts;
- Cleaning of the different machine parts;
- Position of guards and protections.

ELECTRICAL CHECKS

- Correct connections in accordance with wiring diagrams;
- Earth connection of the lift;
- The operation of:
 - Lifting limit switch;
 - Lowering micro-switch;
 - Solenoid valve in the hydraulic system.

HYDRAULIC CHECKS

- Make sure the reservoir is filled with sufficient oil;
- Check for leaks;
- Make sure the cylinder is working properly.

N.B. *If there is insufficient oil, top up the reservoir to the correct level.*

See **Chapter 6 “MAINTENANCE”** for details of the procedure.

CHECKING MOTOR ROTATION DIRECTION

Check that the motor is turning as indicated by the arrow on the control unit hydraulic pump; do this by running the machine momentarily (maximum 2 seconds to avoid damage).

If the hydraulic system is not working properly, consult the fault diagnosis chart in **Chapter 7**.

WARNING

THE FOLLOWING OPERATIONS ARE TO BE PERFORMED EXCLUSIVELY BY TECHNICIANS FROM THE AUTHORISED SERVICE CENTRE specified on the title page.

No-load check (no vehicle on lift)

Check, in particular:

- that the LIFT and LOWERING buttons are working properly;
- that the lift reaches its maximum elevation;
- that there are no undue vibrations in the posts or the cross-pieces;

- that the wedges fit properly into the safety rod slots;
- that the lift limit switch operates properly;
- that the lift cable limit switches are operating properly;
- that the safety wedge release lever is working properly;
- that the electromagnets are working properly.

Perform the above checks and inspections during two or three complete lift and lowering cycles.

Checks with load. Repeat all the above checks with a vehicle on the lift.

After the checks with vehicle, make a visual inspection of the lift and check that the nuts and bolts are tight for the second time.

Chapter 5 OPERATING PRINCIPLES AND USE

Air lock release (Fig. 54)

When this lever is pushed downward, it causes the four wedges to disengage simultaneously.



Fig. 54

LIFTING

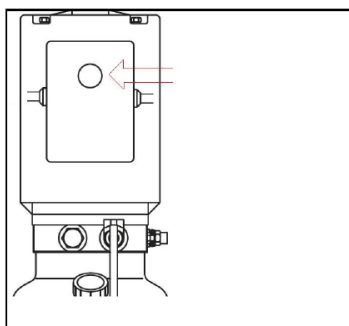

Press the LIFT button on motor until the lift reaches the desired height.

During its travel, the safety wedge release lever will remain in the “rest” position (raised) so that the wedges automatically engage with each slot of the safety rods.

STOPPING

When a vehicle is stopped in the elevated position, the load

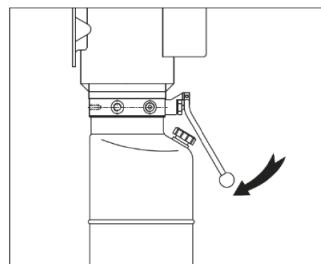

must NEVER be supported by the lift cables, the load must instead be supported by the stopping wedges which must therefore be engaged automatically in the slots on the safety rods.

To obtain the stop function once you have reached the desired height, press lowering handle without activating the safety wedge release lever.

The downward movement will be automatically interrupted as soon as the wedges encounter the first slot during the initial lowering.

LOWERING

Before performing a lowering maneuvers disengage the wedges, press the lift button on motor so that the lift rises about 3cm.

Push the release lever downward and, at the same time, press LOWERING handle to activate the lowering solenoid valve.

If the platform should encounter an obstruction during its lowering the sensors that activate the lift cable slack safety device will operate and stop the lowering movement.

Chapter 6 MAINTENANCE

IMPORTANT

For a longer life of the platforms preserving their good state it is compulsory to carry out the following maintenance:

- Prevent or repair scratches that cut the coat of paint
- Immediately clean possible drops of acid or corrosive oils
- Constantly wipe them dry from water, especially during the winter, because water contains salt

WARNING

Maintenance operations must be performed EXCLUSIVELY BY EXPERT PERSONNEL WITH A COMPLETE WORKING KNOWLEDGE OF THE LIFT.

When servicing the lift use all necessary or useful precautions to **PREVENT ACCIDENTAL STARTING OF THE UNIT**:

- The main switch on the control panel **MUST BE LOCKED OUT IN POSITION "0"**; see Fig. 54.
- THE LOCKOUT KEY must be kept by the MAINTENANCE FITTER for the full duration of the work. (Fig. 55)

Remember:

- **MAIN POSSIBLE POTENTIAL HAZARDS**
- **SAFETY INSTRUCTIONS IN CHAPTER 3 "SAFETY"**.
- **RISK OF ELECTRIC SHOCK on the machine supply terminal box.**

DO NOT ATTEMPT TO ADJUST OR LUBRICATE PARTS OF THE LIFT WHILE THEY ARE IN MOTION.

AFTER EACH MAINTENANCE INTERVENTION REMEMBER TO REFIT THE GUARDS AND REFIT OR REACTIVATE GUARDS AND PROTECTIONS THAT WERE REMOVED OR DISABLED TO MAKE THE MAINTENANCE WORK EASIER.

IMPORTANT

for optimal maintenance of the lift:

- Use only original spare parts and the right tools for the job; make sure the tools are in good condition.

- Observe the maintenance intervals recommended in the manual; these times are guidelines and should be construed as the maximum intervals between each intervention.
- Properly executed preventative maintenance calls for constant attention and surveillance of the machine. Immediately check the cause of any anomalies such as undue noise, overheating, leakage of fluids, etc..

Pay particular attention to:

- the condition of the lifting organs (lift cables, cylinder, hydraulic power unit);
- and the safety devices (microswitches, safety wedges).

For correct maintenance refer to the following documents supplied by the lift manufacturer:

- Complete functional diagram of the electrical equipment and ancillary equipment, together with indication of the power supply connections;
- Hydraulic circuit diagram with list of components and pressure setting values;
- Exploded view with all necessary information for ordering spare parts;
- List of possible causes of faults and recommended solutions (*chapter 7 of the manual*).

PERIODIC MAINTENANCE SCHEDULE

To keep the lift working at optimal efficiency levels observe the recommended maintenance schedule.

If you fail to perform maintenance at the recommend times the manufacturer isn't liable for any damage under the terms of the warranty.

NOTE:

The schedule indicated assumes normal operating conditions; in particularly hostile conditions, intervals between the operations should be reduced.

ALL MAINTENANCE WORK MUST BE PERFORMED WITH THE LIFT STATIONARY, THE POWER SUPPLY DISCONNECTED AND A LOCKOUT ON THE MAIN SWITCH.

EVERY MONTH...**1 - HYDRAULIC POWER UNIT.**

- Check oil level using the dipstick fixed to the filler cap. Top up if necessary through the filler hole until the oil is at the recommended level. Refer to *page 10 "SPECIFICATIONS"* for information on the type of oil to use.
- After the first 40 hours of duty check the level of contamination of the filter and the oil. (Clean the filter and change the oil if contamination is significant).

2 - HYDRAULIC CIRCUIT

- Make sure there are no oil leaks from the various lines connecting the hydraulic power unit and the lift cylinder or from the lift cylinder seals.

If you notice oil leaks from the cylinder check the seals and replace them if necessary.

EVERY 3 MONTHS...**1 - ANCHOR BOLTS**

Check the tightness of the anchor bolts in the baseplates with a torque wrench and make sure they are properly torqued.

2 - LIFT CABLES

- Check the tightening of the U bolts that hold the lifting cables (35 Nm).
- Check that the lift is leveled; if necessary adjust the cables tension.
- Check that the lock nuts of the cable tie rods and the lock nuts of the safety rods are tight.
- Check the condition of the pulleys and relative sheaves.
- Brush the lift cables with grease to avoid rusting and consequent weakening.

Grease type: BRILUBE 30 or equivalent.

The grease must be taken from sealed and/or well conserved packages. Do not use grease that is too old or has undergone chemical changes to avoid irreversible damage to the lift cables.

- Check lift cable wear by measuring the diameter and checking for possible broken strands or other damage.

WARNING

THE STEEL CABLE HAS LIFTING AND SAFETY FUNCTIONS. If in doubt or when you need to change the cables, CONTACT YOUR NEAREST AUTHORISED SERVICE CENTRE.

3 - HYDRAULIC PUMP

- Make sure that the hydraulic power unit pump does not change tone during steady-state operation and make sure that the pump fixing bolts are properly torqued.

4 - SAFETY SYSTEM

- Check the operation and efficiency of the safety devices and the wear of the safety wedges and safety rods. Oil the pivot pins of the safety wedges. If excessively worn, replace the wedges and/or the rods.

5 - TOP SURFACE OF THE CROSS-PIECES

Keep the top surface of the cross-pieces lubricated with a light film of grease for a better sliding movement of the movable platform.

EVERY 6 MONTHS...**1 - OIL**

Check the oil for contamination or ageing.

Contaminated oil is the main cause of valve malfunctions and will reduce the working life of the gear pumps.

EVERY 12 MONTHS...**1 - GENERAL INSPECTION**

- Visual inspection of all structural and mechanical parts to assure that all is fault-free and in good condition.

2 - ELECTRICAL SYSTEM

- Have the electrical system, including motor, wiring, limit switches, and control panel, checked over by a specialized electrician (***CONTACT THE SERVICE CENTRE***).

3 - HYDRAULIC SYSTEM OIL

Change the oil as follows:

- Lower the lift completely.
- Make sure that the hydraulic cylinder is fully retracted.
- Disconnect the power supply.
- Drain the oil from the circuit by unscrewing the drain plug at the bottom of the reservoir.
- Refit the drain plug.
- Fill the reservoir through the filler hole on the top.
- Make sure the oil is filtered.
- For oil types and characteristics refer to the technical specifications (*chapter 2, page 9*).
- Close the filler plug.
- Connect the lift to the power supply.
- Perform two or three lift—lowering cycles (to a height of 20 - 30cm) in order to fill the circuit with oil.

Oil changes: use only recommended oil brands or equivalents; never use oil that has deteriorated because of excessively long storage.

Dispose of used oil as indicated in *Appendix "A"*.

Chapter 7 TROUBLESHOOTING

Troubleshooting and possible repairs require absolute compliance with ALL THE SAFETY PRECAUTIONS indicated in chapter 6 "MAINTENANCE" and chapter 3 "SAFETY".

Problem	Possible cause	Solution
The lift does not rise when the pushbutton is pressed (motor does not run).	<ul style="list-style-type: none"> ● Burnt fuse ● Line current does not arrive ● Malfunction in the electric plant: <ul style="list-style-type: none"> -broken limit switch -burnt motor 	<ul style="list-style-type: none"> ● Replace fuse ● Connect again ● Call Service Centre
The lift does not rise when the pushbutton is pressed (motor runs)	<ul style="list-style-type: none"> ● Note enough oil ● Drain solenoid valve opened ● Max. pressure valve working ● Leaks in the hydraulic circuit 	<ul style="list-style-type: none"> ● Fill up oil level ● Check manual outlet or change it. ● Check the load and adjust the valve ● Repair the line
Lift continues to rise after having released the up pushbutton.	<ul style="list-style-type: none"> ● Faulty pushbutton. 	<ul style="list-style-type: none"> ● Unplug the lift and call service center.
Lift does not descent	<ul style="list-style-type: none"> ● Foreign object ● Solenoid valve blocked ● Malfunction in the electric plant ● Carriages still lean on security devices ● Block valves have tripped. 	<ul style="list-style-type: none"> ● Remove object ● Change it (Call service center) ● Call service center ● Make the correct descent sequence ● Repair the hydraulic circuit damage.
The lift does not rise to the maximum height	<ul style="list-style-type: none"> ● Oil is not enough 	<ul style="list-style-type: none"> ● Add oil into the power unit oil tank
After having released the up pushbutton, the lift stops and lowers slowly	<ul style="list-style-type: none"> ● Drain valve does not close because it is dirty. ● Defective drain valve. 	<ul style="list-style-type: none"> ● At the same time, set the rise and descent movements, to clean valve. ● Change (Call service center)
The power unit motor overheats	<ul style="list-style-type: none"> ● Motor malfunction ● Wrong voltage 	<ul style="list-style-type: none"> ● Call service center ● Check voltage
Power unit pump is noisy	<ul style="list-style-type: none"> ● Dirty oil ● Wrong assembling 	<ul style="list-style-type: none"> ● Change oil ● Call service center
Oil leakage from cylinder	<ul style="list-style-type: none"> ● Damage gaskets ● Dirt in the plant 	<ul style="list-style-type: none"> ● Change the damaged gaskets ● Clean all parts ● Check the valves are not damaged.

Table 2

APPENDIX A SPECIFIC INFORMATION

DISPOSAL OF USED OIL

Used oil drained from the reservoir of the hydraulic power unit during oil changes is to be treated as a pollutant in accordance with the legislation in force in the country where the lift is installed.

SCRAPPING THE MACHINE

WHEN SCRAPPING THE MACHINE OBSERVE ALL PRECAUTIONS ILLUSTRATED IN CHAPTER 3, ADOPTED ALSO DURING MACHINE ASSEMBLY.

The machine can only be scrapped by authorized technicians, as in the case of assembly.

Used oil must be disposed off in compliance with the methods indicated in appendix "A".

Metal parts of the lift can be disposed of as scrap ferrous material.

In all cases when the machine is scrapped all materials must be disposed in conformity with the laws in force in the country of installation of the machine.

Note also that for tax purposes the effective scrapping of the machine must be documented with reports and forms in compliance with the laws in force in the country of installation.

APPENDIX B HYDRAULIC DIAGRAM

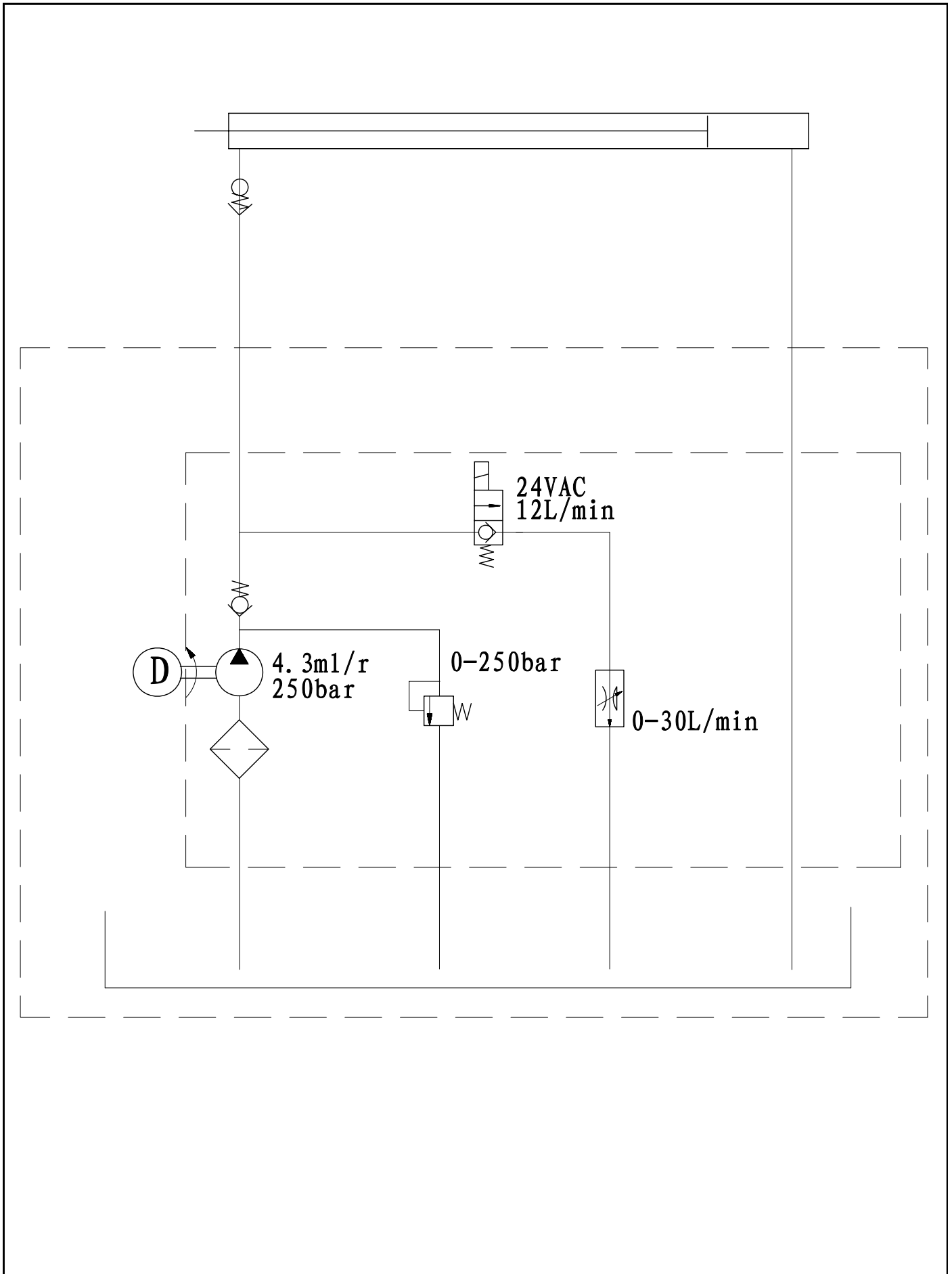

C.3 CODE MEANING

Ref.	Designation	Type & Specifications	Quantity
SA	Power switch	LW39-16RE04/2	1
KM	AC contactor	CJX4-09	1
M	Motor	MS90L-4	1
SQ1	Limit switch	ME 8108	1
SQ2	Safety switch	ME 8108	1
SB	Push button	LA39-B2-11/W	1
SB2	Push button	LA39-B2-11/W	1
H	Buzzer	AD16-22SM/Y DC24V	1
YV	Solenoid	AC 24V	1
FU1/FU2	Fuse	RT18-32 (X) 2A/6A	3
T	Control transformer	JBK3-63 400V/24V	1
U	Rectifier	+KBPC10-10-	2
Q	Breaker	RT18-32 (X) 10A	1

EXPLOSIVE DIAGRAM

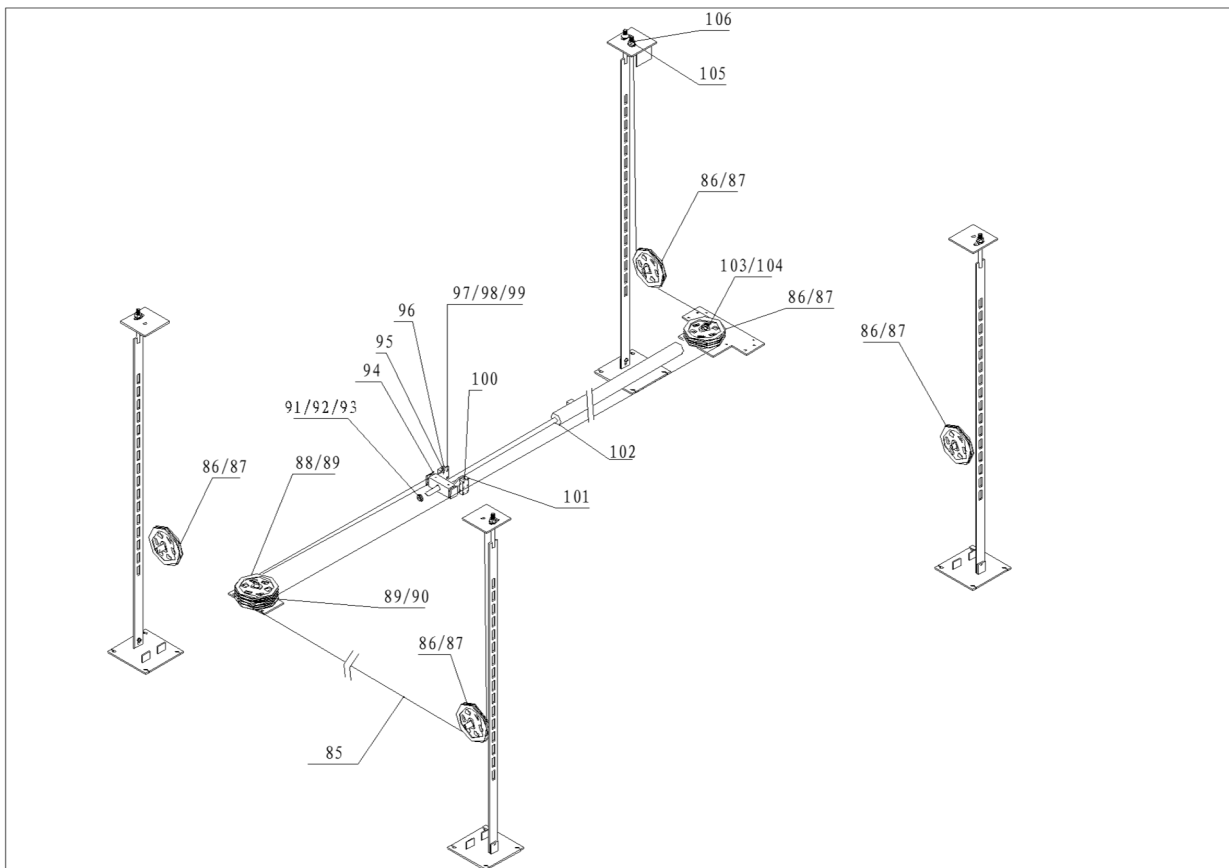
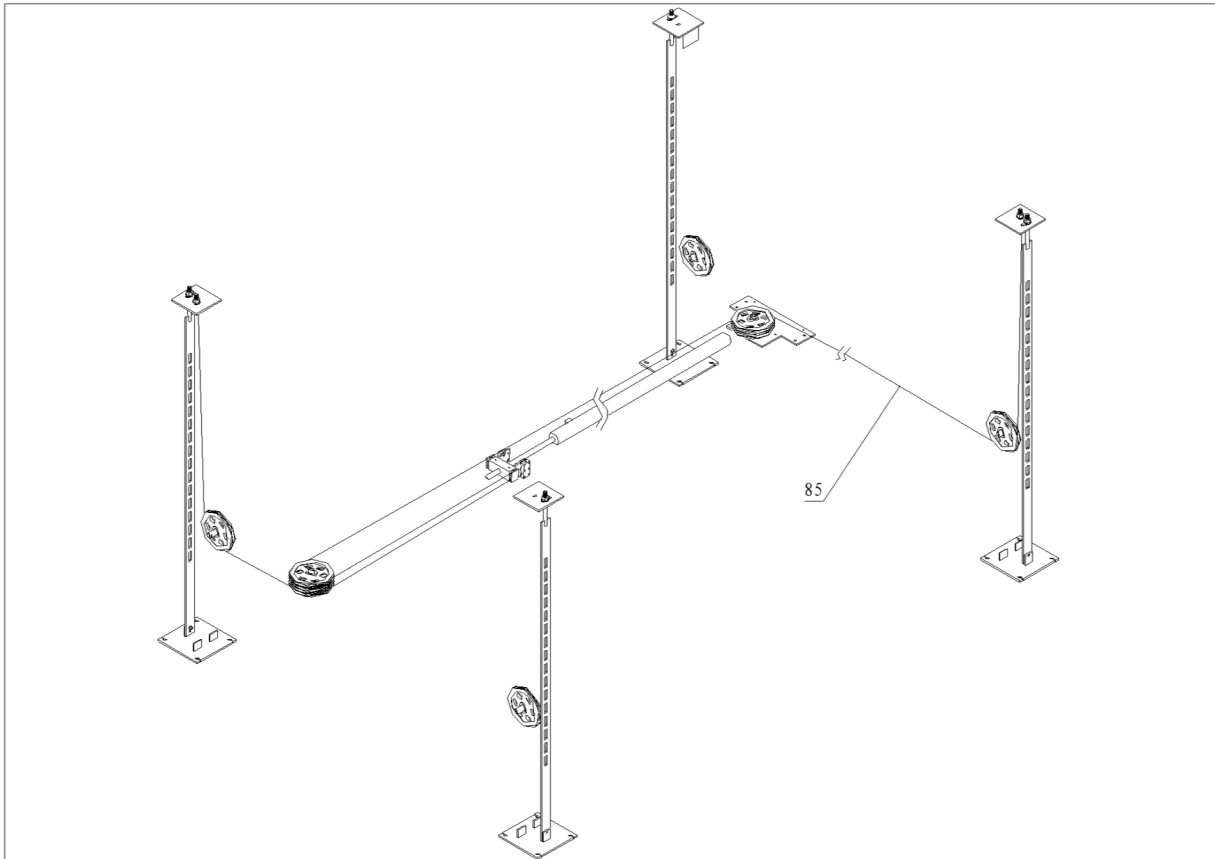

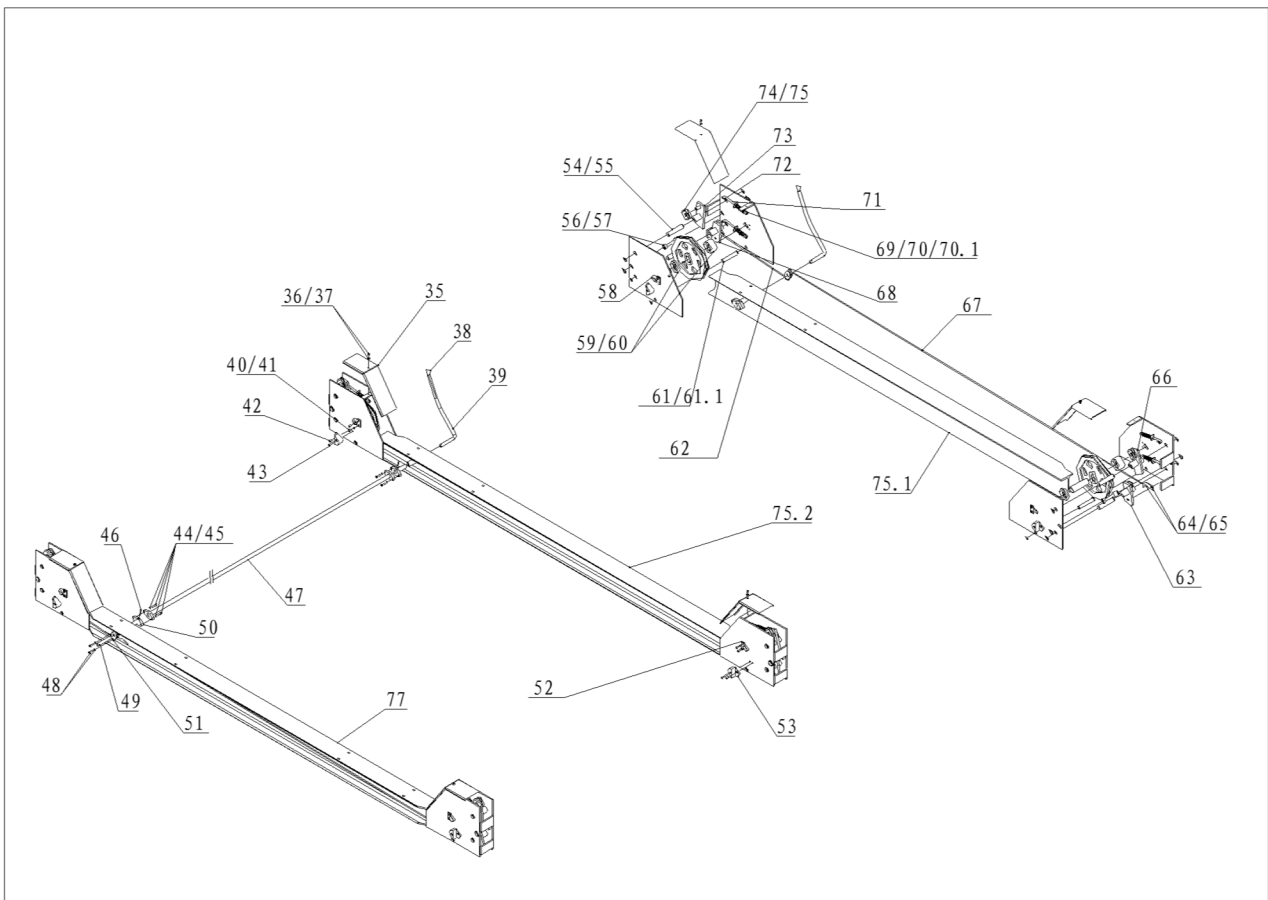
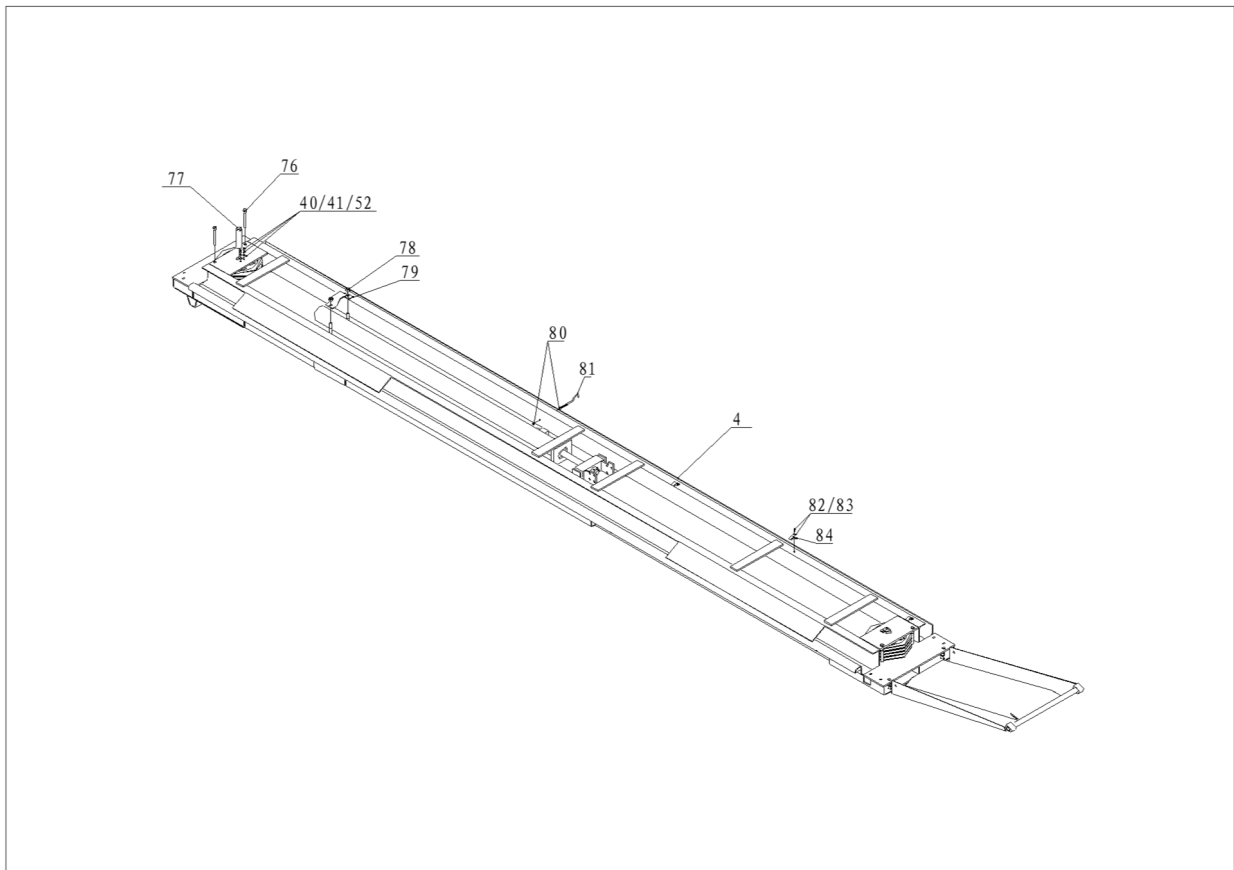

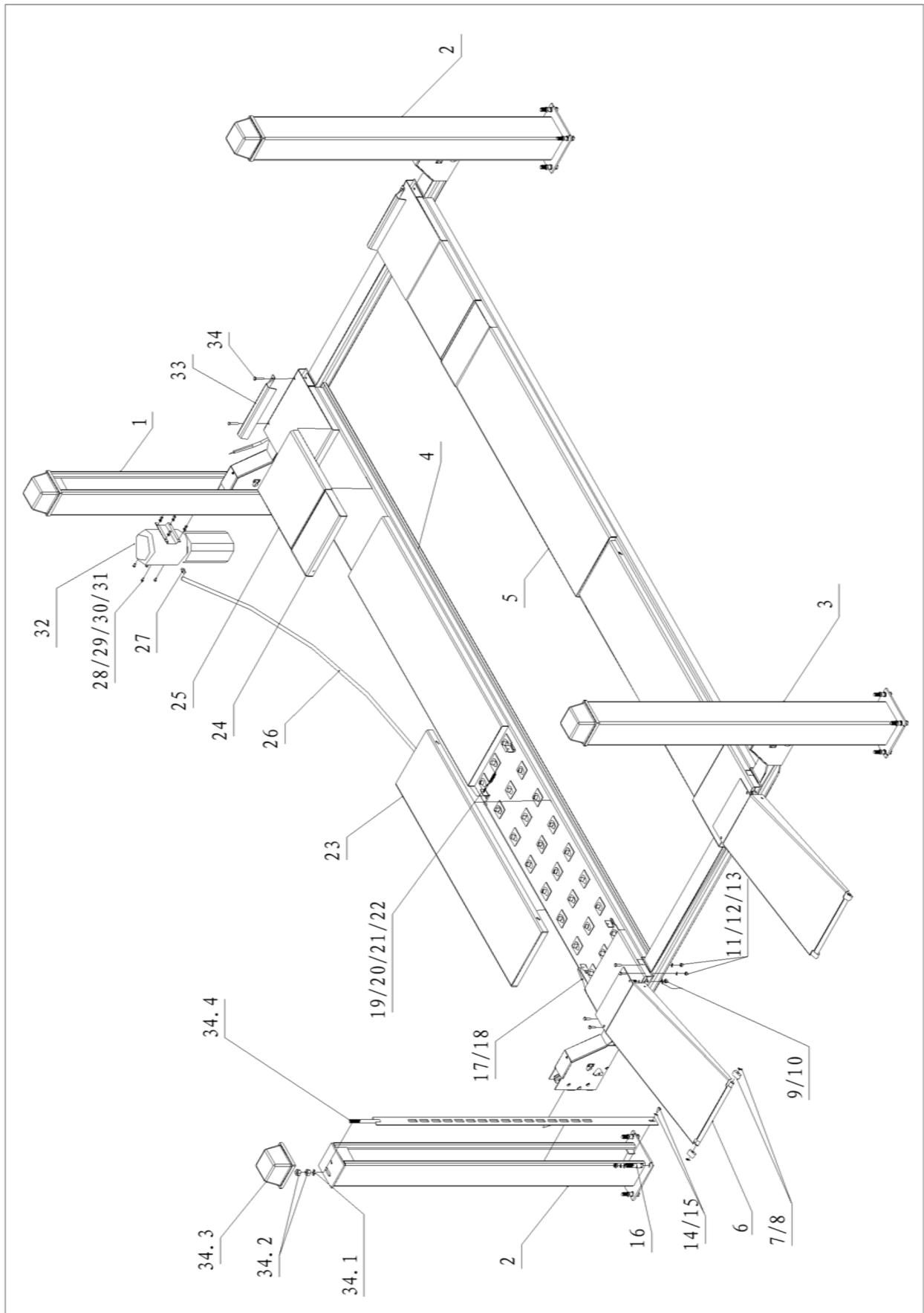

PARTS LIST				
No.	Chart No.	Description	QTY.	Remarks
1	SGM-801-01A-00	column 1	1	jointing parts
2	SGM-801-01BC-00	column 2	2	jointing parts
3	SGM-801-01D-00	column 3	1	jointing parts
4	SGM-803-01A-00	runway 1	1	jointing parts
5	SGM-803-01A-00	runway 2	1	jointing parts
6	SGM-803-02-00	Front board	2	jointing parts
7	SGM-803-03	Small wheel	4	
8	GB894.1-86	Spring washer A	4	D20
9	GB41-86	1 Hexangular bolt C	4	M12
10	GB95-85	flat washer C	8	D12
11	GB5781-86	Hexangular bolt	12	M10X35
12	GB41-86	1 Hexangular bolt C	12	M10
13	GB95-85	flat washer C	12	D10
14	GB70-85	Inner hexangular screw	4	M10X20
15	GB95-85	flat washer C	4	D10
16		anchor bolt	16	M16X140
17	SGM-803-16-00	raw pin parts	4	
18	GB/T15856.1-1995	Cross screw	4	
19	GB41-86	1 Hexangular bolt C	8	M6
20	GB95-85	flat washer C	8	D6
21	SGM-803-08	screw pole 1	8	φ6/Q235
22	GB4142-84	column screw spring	8	D1.6XD12XH88.8
23	SGM-803-07-00	ball bearing cover	2	jointing parts
24	SGM-803-05-00	active board 2	2	jointing parts
25	SGM-803-04-00	active board 1	2	jointing parts
26	SGM-805-21	hydraulic hose	1	L=3450
27	SGM-805-20	cylinder fitting	2	
28	GB5781-86	Hexangular bolt	4	M8X15
29	GB41-86	1 Hexangular bolt C	4	M8
30	GB95-85	flat washer C	4	D8
31	GB93-87	spring washer	4	
32		hydraulic pump	1	
33	SGM-803-13	Front wheel block	2	
34	GB5780-86	Hexangular bolt	4	M10X60
34.1	GB95-85	flat washer C	4	d20
34.2	GB41-86	hexangular nut	8	M20
34.3	SGM-803-01	column cover	4	
34.4	SGM-801-02-00	safety bar	4	
35	SGM-802-09	Hiding board	4	
36	GB818-85	Z Cross bolt	4	M6X10
37	GB95-85	flat washer C	4	D6
38		bakelite ball	1	black
39	SGM-804-08	safety handle	1	φ15/Q235
40	GB818-85	Z Cross bolt	12	M6X12
41	GB93-87	spring washer	12	D6
42	GB823-88	Cross screw	8	M6X12
43	GB823-88	Cross screw	8	M6X35
44	GB70-85	Inner hexangular screw	4	M6X25
45	GB93-87	spring washer	8	D6
46	GB119-86	column pin	4	D4

PARTS LIST				
No.	Chart No.	Description	QTY.	Remarks
47	SGM-804-01-00	Safty transmission pole	1	
48	GB70-85	Inner hexangular screw	4	M6X20
49	SGM-804-11	Safty handle spindle	1	φ15/Q235
50	SGM-804-09	Connection	2	
51	SGM-804-10	Connection 1	2	
52	SGM-802-08	Orientation board	6	
53	SGM-802-07	Rubber block	8	Nylon
54	SGM-802-02	spindle 1	8	
55	GB894.1-86	Spring washer A	16	D20
56	SGM-802-03	spindle 2	4	
57	GB894.1-86	Spring washer A	8	D24
58	SGM-802-04	Wheel spindle	4	
59	SGM-802-06	Spindle bush 2	4	Nylon
60	SGM-802-05	Spindle bush 1	4	Nylon(thick)
61	SGM-802-10	spindle 3	4	
61.1	GB894.1-86	Spring washer A	8	D14
62	SGM-804-12-00	Safty screw pole1	2	jointing parts
63	SGM-804-06B-00	Handle safty 2	2	jointing parts
64	SGM-804-07	Pull block	4	
65	GB41-86	1 Hexangular bolt C	8	M5
66	SGM-804-02B-00	Safety bolck 2	2	jointing parts
67	SGM-804-13-00	Safty screw pole1	2	jointing parts
68	SGM-804-06A-00	Handle safty 1	2	jointing parts
69	GB/T2089-94	constringent spring	8	D1.8XD14X65
70	GB95-85	flat washer C	8	D8
70.1	GB41-86	1 Hexangular bolt C	16	M8
71	SGM-804-04	spring handle	8	plain round φ8/Q235
72	GB91-86	snap ring	8	D2.5X20
73	SGM-804-02A-00	Safety bolck1	2	jointing parts
74	SGM-804-03	Safty idler wheel	4	
75	GB894.1-86	Spring washer A	8	D14
75.1	SGM-802-01A-00	beam 1	1	jointing parts
75.2	SGM-802-01B-00	beam 2	1	jointing parts
76	SGM-805-18	Orientation bolt	4	
77	SGM-805-07	beam wheel 1	2	
78	GB41-86	1 Hexangular bolt C	2	M12
79	SGM-803-A (new)	cylinder hoop	1	
80	GB41-86	1 Hexangular bolt C	2	M6
81	SGM-803-04	Safty transmission pole clasp	1	φ6/Q235
82	GB818-85	Z Cross bolt	3	M5X12
83	GB96-85	Big washer A & C	3	D5
84	SGM-803-15	Pose pump board	3	
85	SGM-805-19	steel cable	2	L=13820
86	SGM-805-01	Beam wheel 1	6	
87		bush 1	6	
88	SGM-805-03	Beam wheel 3	2	
89		bush 2	4	
90	SGM-805-02	beam wheel 2	1	

PARTS LIST				
No.	Chart No.	Description	QTY.	Remarks
91	GB6170-86	hexangular nut	1	M27
92	GB95-85	flat washer C	1	D30
93	GB91-86	snap ring	1	D4X45
94	SGM-805-05-00	Cable stable	1	jointing parts
95	SGM-805-13	cable block 2	1	
96	SGM-805-12	cable block 1	1	
97	GB70-85	inner hexangular screw	10	M8X60
98	GB95-85	flat washer C	10	D8
99	GB93-87	spring washer	10	D8
100	SGM-805-14	Cable block 3	1	
101	SGM-805-15	Cable block 4	1	
102		Hydraulic cylinder	1	
103	SGM-805-11	Set of Beam wheel spindle	1	
104	TB/7940.3-95	Revolving oil cup A	2	
105	GB95-85	flat washer C	4	D20
106	GB6170-86	hexangular nut	8	M20